

Compact Magnetic Non-contact Safety Switches

F3S-TGR-N□C

Magnetic Coded Non-contact switches are designed to interlock hinge, sliding or removal guard doors. All coded Non-contact switches have a LED for easy diagnosis.

- Coded actuator for applications requiring anti tamper switches
- Non-contact = no abrasion = no particles
- Excellent coverage of mechanical tolerances
- Can operate behind stainless steel fittings
- Screw-hole covers support hygienic design (NMPC)
- Conforms to safety categories up to PLe acc. EN ISO 13849-1

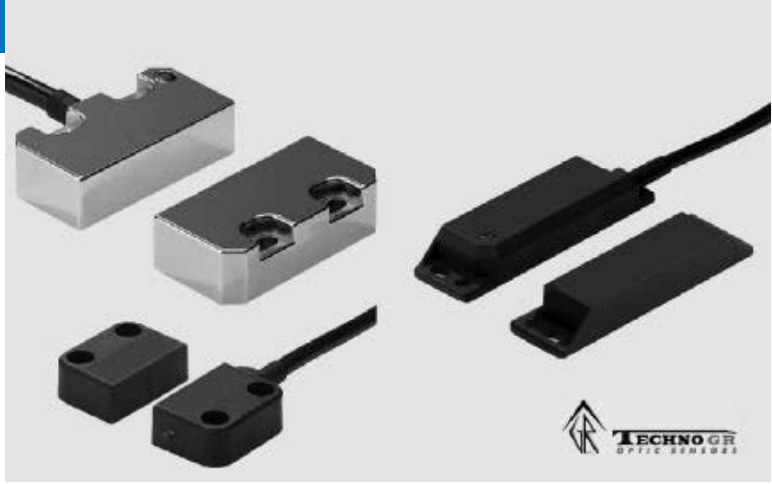

Model Number Structure

F3S-TGR-N□□C-□□-□□

1. Type

- L: Elongated Sensor
- S: Small Sensor
- M: Miniature Sensor

2. Housing Material

- P: Plastic Housing
- M: Stainless Steel Housing

3: Contact configuration

- 20: 2 Normally Closed Contacts (NC)
- 21: 2 Normally Closed Contacts (NC) + 1 Normally Open Contact (NO)

4: Cable Length/connection

- 02: 2 m Cable
- 05: 5 m Cable
- 10: 10 m Cable
- M1J8: M12 male connector, 8pin

4: Cable Length/connection for NMPC

- 02: 2 m Cable, cable exit to the left
- 05: 5 m Cable, cable exit to the left
- 10: 10 m Cable, cable exit to the left
- M1J8: M12 male connector, 8-pin, cable exit to the left

- 02-R: 2 m Cable, cable exit to the right
- 05-R: 5 m Cable, cable exit to the right
- 10-R: 10 m Cable, cable exit to the right
- M1J8-R: M12 male connector, 8-pin, cable exit to the right

Ordering Information

Elongated Sensors	Type	Cable Connection	Contact Configuration
	F3S-TGR-NLPC-20-02	2 m pre-wired	2NC
	F3S-TGR-NLPC-20-05 *	5 m pre-wired	2NC
	F3S-TGR-NLPC-20-10	10 m pre-wired	2NC
	F3S-TGR-NLPC-20-M1J8	M12, 8-pin	2NC
	F3S-TGR-NLPC-21-02	2 m pre-wired	2NC/1NO
	F3S-TGR-NLPC-21-05 *	5 m pre-wired	2NC/1NO
	F3S-TGR-NLPC-21-10	10 m pre-wired	2NC/1NO
	F3S-TGR-NLPC-21-M1J8	M12, 8-pin	2NC/1NO

* Preferred stock items

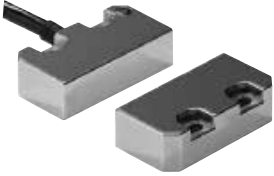
Small Sensor	Type	Cable Connection	Contact Configuration
	F3S-TGR-NSMC-20-02	2 m pre-wired	2NC
	F3S-TGR-NSMC-20-05 *	5 m pre-wired	2NC
	F3S-TGR-NSMC-20-10	10 m pre-wired	2NC
	F3S-TGR-NSMC-20-M1J8	M12, 8-pin	2NC
	F3S-TGR-NSMC-21-02	2 m pre-wired	2NC/1NO
	F3S-TGR-NSMC-21-05 *	5 m pre-wired	2NC/1NO
	F3S-TGR-NSMC-21-10	10 m pre-wired	2NC/1NO
	F3S-TGR-NSMC-21-M1J8	M12, 8-pin	2NC/1NO

* Preferred stock items

Miniature Sensor	Type	Cable Connection	Contact Configuration
	F3S-TGR-NMPC-20-02	2 m pre-wired	2NC
	F3S-TGR-NMPC-20-05 *	5 m pre-wired	2NC
	F3S-TGR-NMPC-20-10	10 m pre-wired	2NC
	F3S-TGR-NMPC-20-M1J8	M12, 8pin	2NC
	F3S-TGR-NMPC-21-02	2 m pre-wired	2NC/1NO
	F3S-TGR-NMPC-21-05 *	5 m pre-wired	2NC/1NO
	F3S-TGR-NMPC-21-10	10 m pre-wired	2NC/1NO
	F3S-TGR-NMPC-21-M1J8	M12, 8pin	2NC/1NO





Optional cable exit to the right is available for F3S-TGR-NMPC-types. Name extension is '-R'. Please contact your Omron distributor

* Preferred stock items

Accessories

Cables 8-pin	2 m	Y92E-M12PURSH8S2M-L
	5 m	Y92E-M12PURSH8S5M-L
	10 m	Y92E-M12PURSH8S10M-L
	25 m	Y92E-M12PURSH8S25M-L
T-Connector connection cable	for M12 connector - types	F39-TGR-NT
	0.6 m, M12-8pin	Y92E-M12FSM12MSPURSH806M-L
	2 m, M12-8pin	Y92E-M12FSM12MSPURSH82M-L
	5 m, M12-8pin	Y92E-M12FSM12MSPURSH85M-L
	10 m, M12-8pin	Y92E-M12FSM12MSPURSH810M-L
Actuators	for F3S-TGR-NLPC	F3S-TGR-NLPC-A
	for F3S-TGR-NSMC	F3S-TGR-NSMC-A
	for F3S-TGR-NMPC	F3S-TGR-NMPC-A

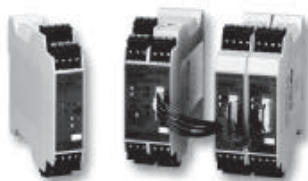
Control units

Safety relay units	<p>G9SA</p> 	<p>G9SA-301 G9SA-501 G9SA-321-T075 G9SA-321-T15 G9SA-321-T30</p>
	<p>G9SB</p> 	<p>G9SB-2002-C G9SB-2002-A G9SB-200-B G9SB-200-D G9SB-3012-A G9SB-301-B G9SB-3012-C G9SB-301-D</p>
	<p>G9SX</p> 	<p>G9SX-BC202-R_ G9SX-AD322-T15-R_ G9SX-AD322-T150-R_ G9SX-ADA222-T15-R_ G9SX-ADA222-T150-R_</p>
Programmable standalone controllers	<p>G9SP-N</p> 	<p>G9SP-N10S G9SP-N10D G9SP-N20S</p>
Programmable network controllers	<p>NE1A</p> 	<p>NE1A-SCPU01-V1 NE1A-SCPU02</p>

Specifications

Mechanical Data

		Elongated Sensor	Small Sensor	Miniature Sensor
Recommended setting gap		5 mm		
Operating distance	OFF → ON (Sao)	12 mm Close		8 mm Close
	ON → OFF (Sar)	17 mm Open		12 mm Open
Tolerance in misalignment		5 mm in any direction from 5 mm setting gap		
Actuator approach speed	Min.	4 mm/s		
	Max.	1,000 mm/s		
Switching frequency	Max.	1 Hz		
Operating temperature		-25°C ... +80°C	-25°C ... +105°C	-25°C ... +80°C
Enclosure protection	Flying lead	IP67	IP69K	IP67
	M12 connector	IP67		
Material		Black Polyester	Stainless Steel 316	Black Polyester
Mounting bolts		2 × M4 recommended		
Tightening torque		1 Nm		
Mounting position		any		
Mechanical life expectancy		10,000,000 cycles		
Electrical life expectancy (not PFHd)		3,300,000 cycles @ 24 VDC/100 mA		
Cable diameter and material		6 mm PVC		

Electrical Data

		Elongated Sensor	Small sensor	Miniature Sensor
Power supply		24 VDC ±15%		
Power consumption	Max.	50 mA		
Switching current	Min.	1 mA @ 10 VDC		
Rated loads	NC contacts	100 mA @ 24 VDC		
	NO contacts	100 mA @ 24 VDC		
Insulation resistance		100 MΩ		
Rated insulation voltage		250 VAC		
Output type		electronic output (potential-free optocoupler output)		

Approved Standards

- EN standards certified by TÜV Rheinland
- EN ISO 13849-1
- EN 954-1
- EN 62061
- EN 60204-1
- EN/IEC 60947-5-3
- UL 508, CSA C22.2
- BS 5304
- EN 1088-1 conformance

Dimensions

Elongated sensor (Sensor/Actuator)

F3S-TGR-NLPC

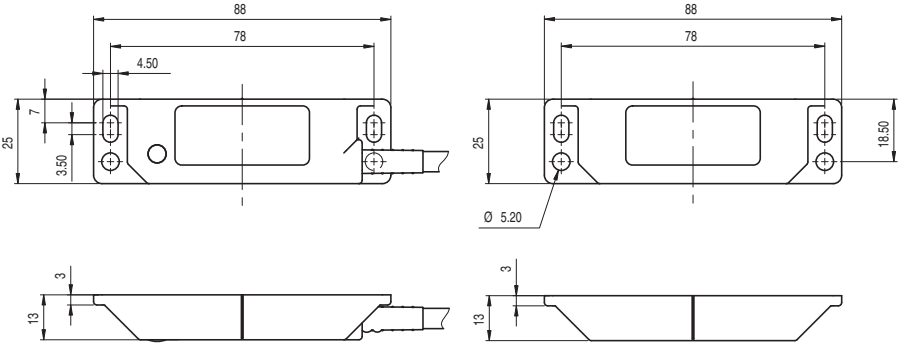

Small sensor (Sensor/Actuator)

F3S-TGR-NSMC

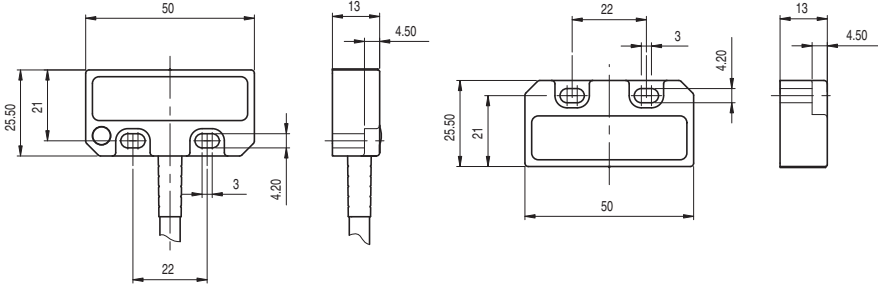

Miniature sensor (Sensor/Actuator)

F3S-TGR-NMPC

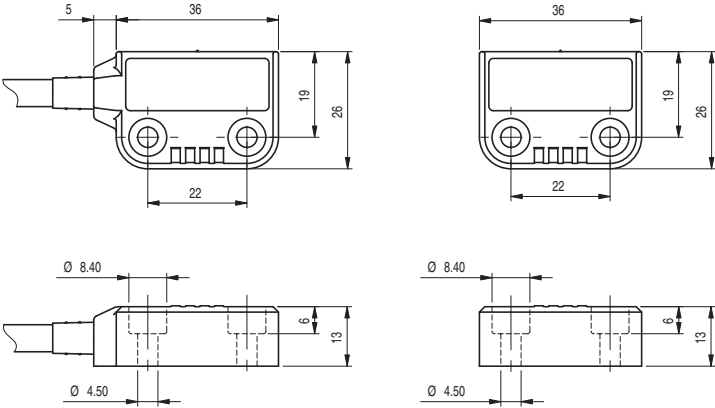

Connection diagram

Cable version

Pin No.	Signal name
red	+24 VDC
blue	GND
black	NC Channel 1, +
white	NC Channel 1, -
yellow	NC Channel 2, +
green	NC Channel 2, -
brown	Aux. NO Channel +
orange	Aux. NO Channel, -

M1J8-Connector version (M12 male)

Pin No. (male side)	Signal name	Wire color (Y92E-M12PURSH8_M-L)
2	+24 VDC	Brown
3	GND	Green
7	NC Channel 1, +	Blue
1	NC Channel 1, -	White
4	NC Channel 2, +	Yellow
6	NC Channel 2, -	Pink
5	NO Channel +	Grey
8	NO Channel, -	Red

Operating characteristics

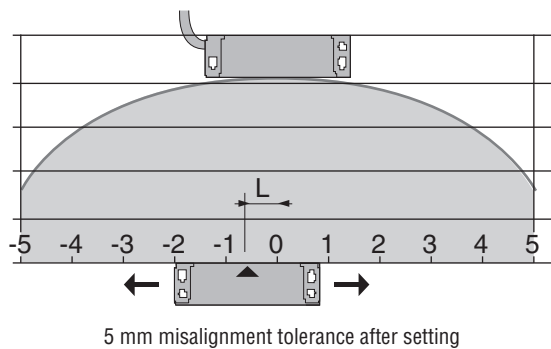

Wiring examples

G9SA

Single Sensor Application with G9SA-301
(up to Safety PLe acc. EN ISO 13849-1)

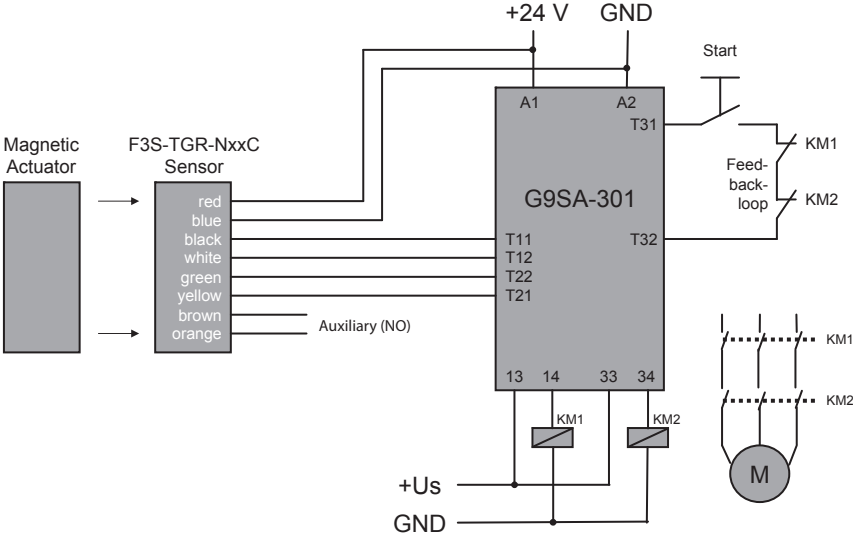

Series connection Application, up to 3 Sensors with G9SA-301
(up to Safety PLd acc. EN ISO 13849-1)

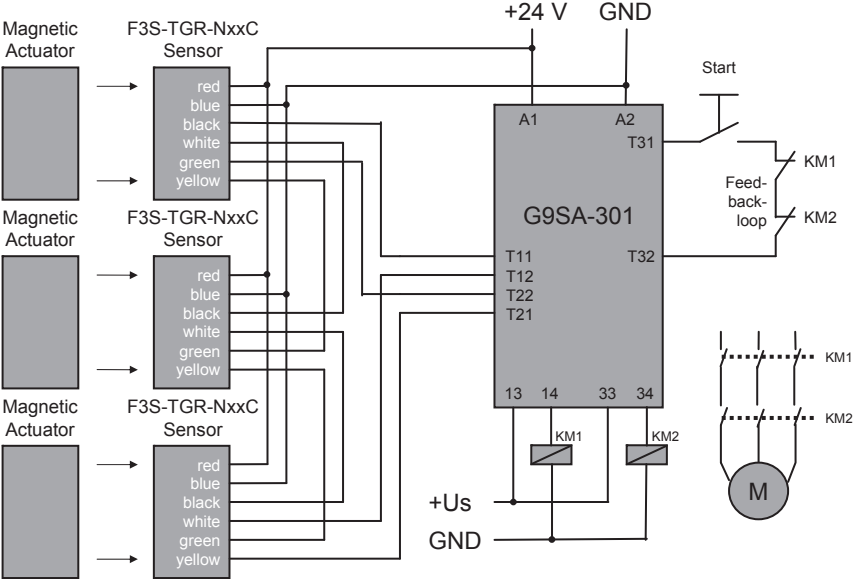

G9SB

Single Sensor Application with G9SB-2002-C
(up to Safety PLe acc. EN ISO 13849-1)

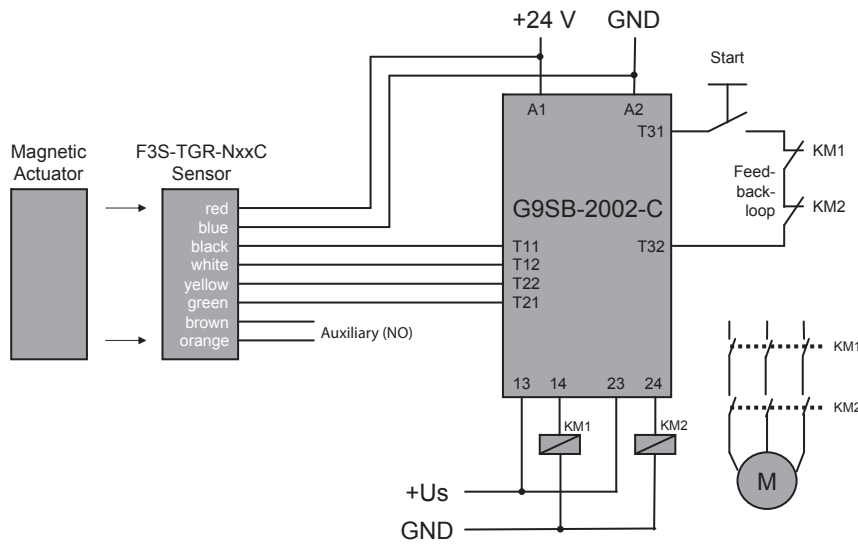

Series connection Application, up to 3 Sensors with G9SB-2002-C
(up to Safety PLd acc. EN ISO 13849-1)

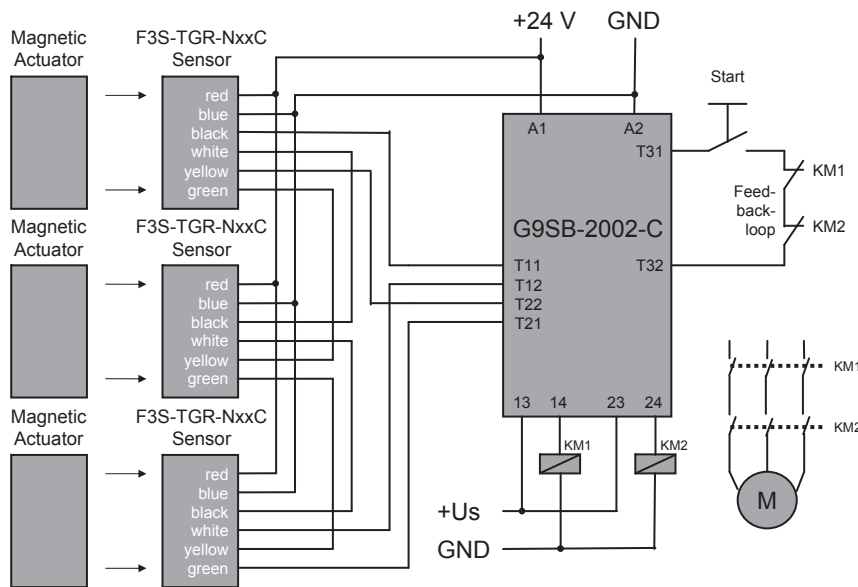

G9SX

Single Sensor Application with G9SX-AD322-T15
(up to Safety PLe acc. EN ISO 13849-1)

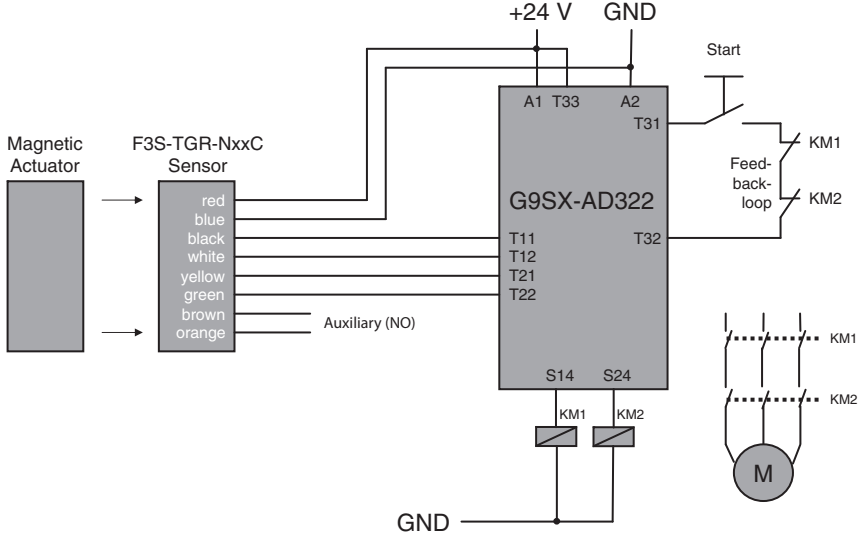

Series connection Application, up to 3 Sensors with G9SX-AD322-T15
(up to Safety PLd acc. EN ISO 13849-1)

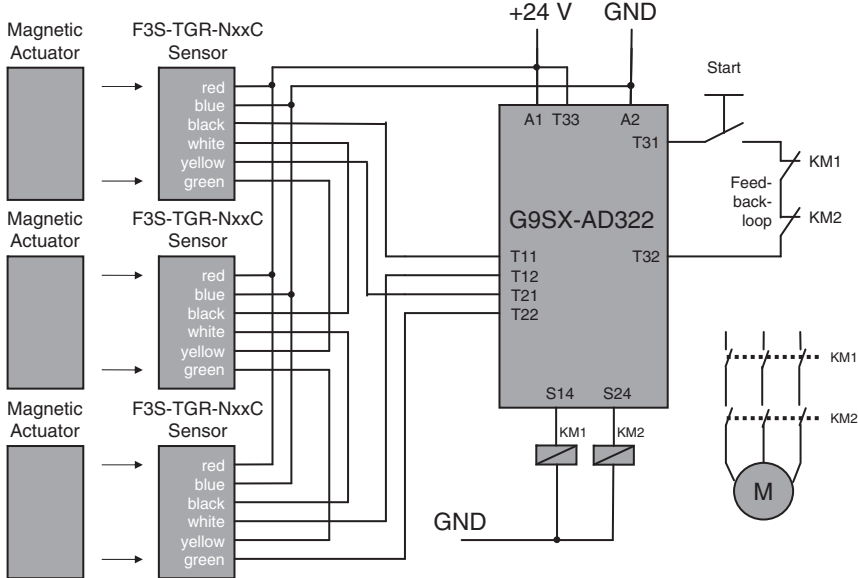

DeviceNet Safety NE1A and DST1-I/O-Terminals

Single Sensor Application with NE1A and DST1-Safety-IO

(up to Safety PLe acc. EN ISO 13849-1)

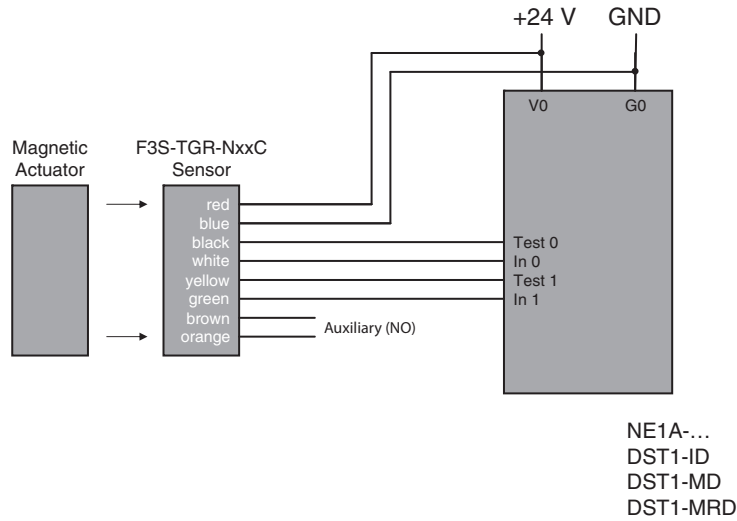

Series connection Application, up to 3 Sensors with NE1A or DST1-Safety-IO

(up to Safety PLd acc. EN ISO 13849-1)

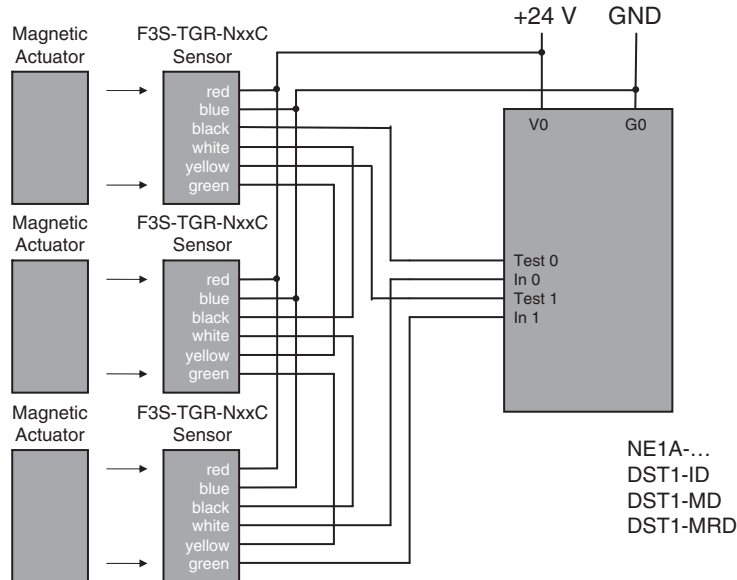

Application with multiple Sensors with NE1A or DST1-Safety-IO

(up to Safety PLe acc. EN ISO 13849-1)

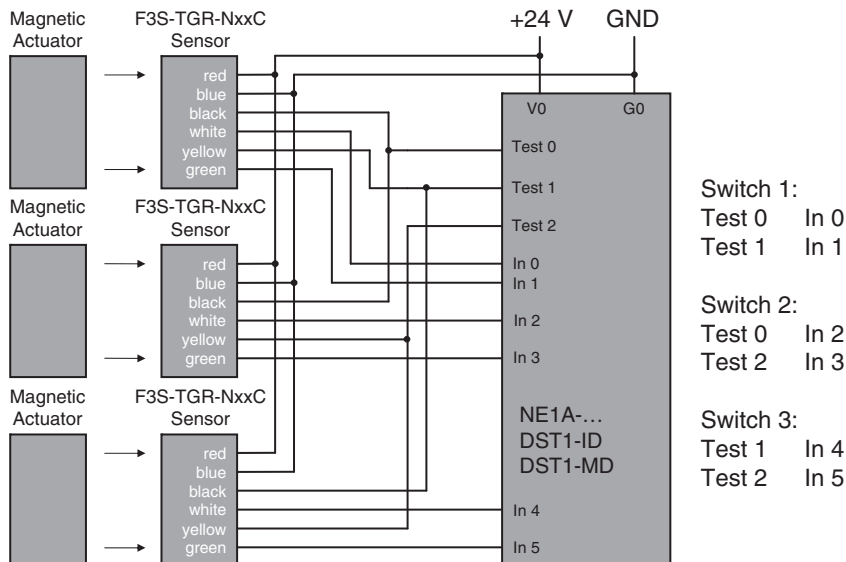

T-Connector and Connection Cable

Series connection with 2 or 3 Sensors for example with G9SA-301
(up to Safety PLd acc. EN ISO 13849-1)

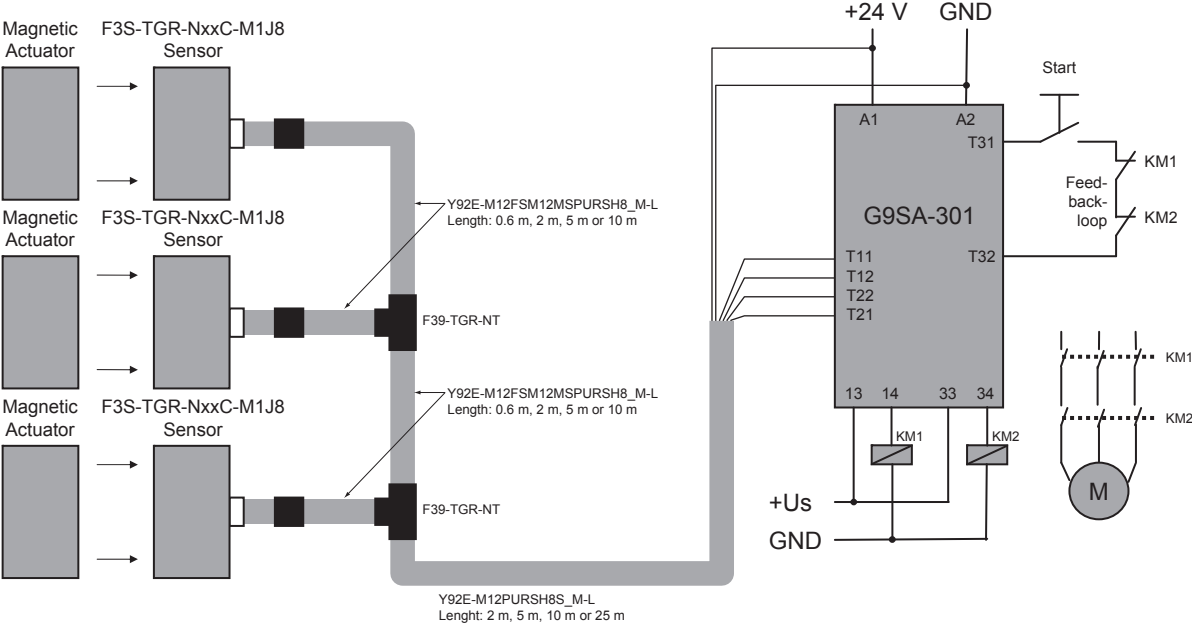

Safety Precautions

WARNING

Be sure to turn OFF the power before performing wiring. Do not touch charge parts (e.g., terminals) while power is ON. Doing so may result in electric shock.



Do not allow the actuator to come close to the switch with the door open. Doing so may cause machinery to start operating and may result in injury.



Keep actuators (magnets) away from magnetically sensitive equipment like PC harddisks, floppy disks etc. The magnetic field of the magnet will damage existing data.



CAUTION

Use guard stops in the way shown below to ensure that the switch and actuator do not make contact when the guard door is closed.

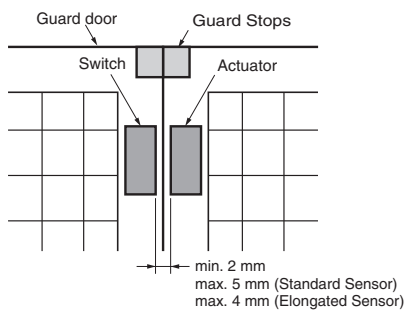

Application Precautions

- Do not use the product in locations subject to explosive or flammable gases.
- Do not use load currents exceeding the rated value.
- Be sure to wire each conductor correctly.
- Be sure to confirm correct operation after completing mounting and adjustment.
- Do not drop or attempt to disassemble the product.
- Be sure to use the correct combination of switch and actuator.
- Use a power supply of the specified voltage. Do not use power supplies with large ripples or power supplies that intermittently generate incorrect voltages.
- Capacitors are consumable and require regular maintenance and inspection.

Precautions for Safe Use

Mounting Direction of Switch and Actuator

The Sensor will not operate properly if the switch and actuator come towards each other diagonally. The Sensor will, however, operate properly if the switch and actuator come towards each other head-on, horizontally or vertically (as long as the faces have the same orientation).

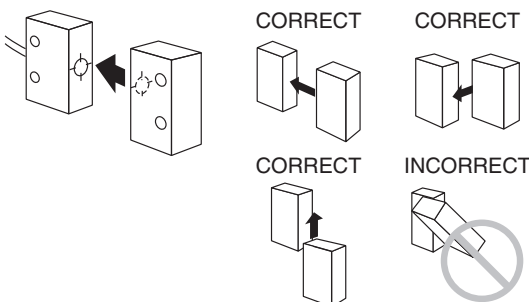

ALL DIMENSIONS SHOWN ARE IN MILLIMETERS.

To convert millimeters into inches, multiply by 0.03937. To convert grams into ounces, multiply by 0.03527.

Mutual Interference

If the switch and actuator are mounted in parallel, be sure to separate them by at least 25 mm, as shown below.

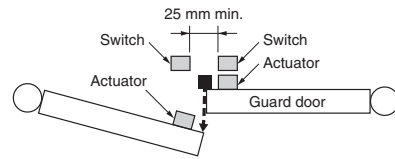

Using for Hinged Doors

On hinged doors, install the Sensor at an opening edge as shown below.

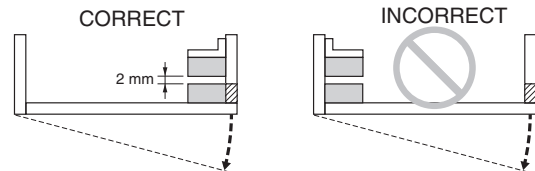

Solvents

Ensure that solvents, such as alcohol, thinner, trichloroethane, or gasoline do not adhere to the product. Solvents may cause markings to fade and components to deteriorate.

Installation Location

Do not install the product in the following locations. Doing so may result in product failure or malfunction.

- Locations subject to direct sunlight
- Locations subject to humidity levels outside the range 35% to 85% or subject to condensation due to extreme temperature changes
- Locations subject to corrosive or flammable gases
- Locations subject to shocks or vibration in excess of the product ratings
- Locations subject to dust (including iron dust) or salts

Take appropriate and sufficient countermeasures when using the product in the following locations.

- Locations subject to static electricity or other forms of noise
- Locations subject to possible exposure to radioactivity
- Locations subject to power supply lines
- It is advisable to mount the switches on non ferrous materials. The presence of ferrous material can effect switching sensitivity.

Wiring

Perform wiring using wire with the following dimensions.

Stranded wire: 2.5 mm²

Solid wire: 4.0 mm²

Tighten the terminal screws with the specified torque. Not doing so may result in malfunction or abnormal heat generation.