



# INVERTER INSTRUCTION MANUAL

---

*Brake Unit*

**FR-BU2-1.5K to 55K**  
**FR-BU2-H7.5K to H75K**

Thank you for choosing this Mitsubishi Inverter option unit.

This instruction manual gives handling information and precautions for use of this equipment. Incorrect handling might cause an unexpected fault. Before using the equipment, please read this manual carefully to use the equipment to its optimum performance.

Please forward this manual to the end user.

## This section is specifically about safety matters

Do not attempt to install, operate, maintain or inspect this product until you have read through this instruction manual and appended documents carefully and can use the equipment correctly. Do not use this product until you have a full knowledge of the equipment, safety information and instructions.

In this instruction manual, the safety instruction levels are classified into "WARNING" and "CAUTION".



Assumes that incorrect handling may cause hazardous conditions, resulting in death or severe injury.



Assumes that incorrect handling may cause hazardous conditions, resulting in medium or slight injury, or may cause physical damage only.

Note that even the  CAUTION level may lead to a serious consequence according to conditions. Please follow the instructions of both levels because they are important to personnel safety.

## SAFETY INSTRUCTIONS

### 1. Electric Shock Prevention



- While power is on or when the brake unit is running, do not open the front cover. You may get an electric shock.
- Do not run the brake unit with the front cover removed. Otherwise, you may access the exposed high-voltage terminals and charging part and get an electric shock.
- Even if power is off, do not remove the front cover except for wiring or periodic inspection. You may access the charged inverter connected to the brake unit and get an electric shock.
- Before starting wiring or inspection, check to make sure that the 3-digit LED brake unit monitor is off, wait for at least 10 minutes after the power supply has been switched off, and check to make sure that there are no residual voltage using a tester or the like. The brake unit connected to the brake unit is charged with high voltage for some time after power off and it is dangerous.
- Must be earthed (grounded).
- Any person who is involved in the wiring or inspection of this equipment should be fully competent to do the work.
- Always install the brake unit before wiring. Otherwise, you may get an electric shock or be injured.
- Do not operate a switch with wet hands. You may get an electric shock.
- Do not subject the cables to scratches, excessive stress, heavy loads or pinching. Otherwise you may get an electric shock.

### 2. Fire Prevention



- Mount the brake unit and resistor unit to incombustible material. Installing it to combustible materials directly or near combustible materials can cause a fire.
- Turn off power when an alarm signal is output. Otherwise, the brake resistor may excessively overheat due to damage of the brake transistor and such, causing a fire.
- Do not connect the resistor unit directly to the DC terminals P/+ and N/-. This could cause a fire.

### 3. Injury Prevention



- Apply only the voltage specified in the instruction manual to each terminal. Otherwise, burst, damage, etc. may occur.
- Ensure that the cables are connected to the correct terminals. Otherwise, burst, damage, etc. may occur.
- Always make sure that polarity is correct to prevent damage, etc. Otherwise, burst, damage may occur.
- While power is on or for some time after power-off, do not touch the brake resistor as it will be extremely hot. Doing so can cause burns.

#### 4. Additional Instructions

Also note the following points to prevent an accidental failure, injury, electric shock, etc.

##### 1) Transportation and mounting

<b>⚠ CAUTION</b>		
<ul style="list-style-type: none"> <li>• Transport the product using the correct method that corresponds to the weight. Failure to observe this could lead to injuries.</li> <li>• Do not stack the brake unit boxes higher than the number recommended.</li> <li>• Install the product in a place which can withstand its weight according to the information in the instruction manual.</li> <li>• Do not install or operate the option unit if it is damaged or has parts missing.</li> <li>• When carrying the brake unit, do not hold it by the front cover. It may fall off or fail.</li> <li>• Do not stand or rest heavy objects on the product.</li> <li>• Check that the mounting orientation is correct.</li> <li>• Prevent screws, metal fragments or other conductive bodies or oil or other flammable substance from entering the brake unit.</li> <li>• As this brake unit is a precision instrument, do not drop or subject it to impact.</li> <li>• Use the brake unit under the following environmental conditions: Failure to follow may damage the product.</li> </ul>		
<b>Environment</b>	Ambient temperature	-10°C to 50°C (non-freezing)
	Ambient humidity	90% RH or less (non-condensing)
	Storage temperature	-20°C to 65°C *1
	Atmosphere	Indoors (free from corrosive gas, flammable gas, oil mist, dust and dirt)
	Altitude/vibration	Maximum 1000m above sea level, 5.9m/s <sup>2</sup> or less (conforms to JIS C 60068-2-6)
*1 Temperature applicable for a short time, e.g. in transit.		

##### (2) Trial run

<b>⚠ CAUTION</b>	
<ul style="list-style-type: none"> <li>• Before starting operation, confirm and adjust the parameters. Setting parameter different from the one set in the resistor connected may not exhibit the best performance or may cause resistor overheat or alarm.</li> </ul>	

##### 3) Usage

<b>⚠ WARNING</b>	
<ul style="list-style-type: none"> <li>• Do not modify the equipment.</li> <li>• Do not perform parts removal which is not instructed in this manual. Doing so may lead to fault or damage of the product.</li> </ul>	

##### (4) Emergency stop

<b>⚠ CAUTION</b>	
<ul style="list-style-type: none"> <li>• Provide a safety backup such as an emergency brake which will prevent the machine and equipment from hazardous conditions if the inverter and brake unit fail.</li> </ul>	

##### (5) Maintenance, inspection and parts replacement

<b>⚠ WARNING</b>	
<ul style="list-style-type: none"> <li>• Do not test the brake unit with a megger (measure insulation resistance).</li> </ul>	

##### (6) Disposal

<b>⚠ CAUTION</b>	
<ul style="list-style-type: none"> <li>• Treat as industrial waste.</li> </ul>	

##### (7) General instruction

<p>Many of the diagrams and drawings in this Instruction Manual show the products without a cover, or partially open. Never operate the products in this manner. Always replace the cover and follow this Instruction Manual when operating the products.</p>	
---------------------------------------------------------------------------------------------------------------------------------------------------------------------------------------------------------------------------------------------------------------	--

## Brake unit (FR-BU2 type)

When running the motor with the FR series inverter, use this option unit when a large brake torque is necessary such as when the motor is made to run by the load, quick deceleration is required, etc.

Following three types of brake resistor as in the table below can be connected to this option unit. FR-BU2 type brake unit can be used as substitute of the existing brake units (BU type, FR-BU-(H) type, MT-BU5 type).

Do not operate the conventional brake unit and FR-BU2 in parallel. Doing so could cause an alarm or failure. Change all units to the FR-BU2 to operate in parallel and connect the master/slave signal.

Compatible Brake Resistor and Resistor Unit	Conventional Brake Unit
GRZG type brake resistor	BU type
FR-BR-(H) type resistor unit	FR-BU-(H)
MT-BR5 type resistor unit	MT-BU5 type

Perform wiring and parameter setting referring to *page 15* as the wiring method and parameter setting method differ according to the brake resistor combined.

# CONTENTS

<b>1</b>	PRODUCT CHECKING AND PARTS IDENTIFICATION.....	1
<b>2</b>	INSTALLATION.....	2
<b>3</b>	WIRING.....	4
3.1	Terminals.....	4
3.1.1	Brake unit.....	4
3.1.2	Resistor unit.....	11
3.2	Combinations of Brake Resistors for Brake Unit and Used Wires.....	13
3.3	External Connection Diagram.....	14
3.3.1	Connection with the inverter.....	14
3.4	Connection Example with the GRZG Type Brake Resistor.....	16
3.4.1	When connecting one inverter and one brake unit.....	16
3.4.2	When connecting several brake units to one inverter.....	18
3.4.3	Master/slave operation when connecting several brake units.....	19
3.5	FR-BR-(H) Connection Example with Resistor Unit.....	21
3.5.1	When connecting one inverter and one brake unit.....	21
3.5.2	When connecting several brake units to one inverter.....	22
3.5.3	Master/slave operation when connecting several brake units.....	23
3.6	Connection Example with MT-BR5 Type Resistor Unit.....	24
3.6.1	When connecting one inverter and one brake unit.....	24
3.6.2	When connecting several brake units to one inverter.....	25
3.6.3	Master/slave operation when connecting several brake units.....	26
3.7	Wiring Instructions.....	28
<b>4</b>	OPERATION.....	30
4.1	Control Panel.....	30
4.2	Basic Operation.....	31
4.3	Parameter List.....	32
4.3.1	Mode switchover (Pr.0).....	33
4.3.2	Multi-function monitor display (Pr.1, Pr.78).....	34
4.3.3	Input terminal function selection (Pr.2, Pr.3).....	36
4.3.4	Parameter write disable selection (Pr. 77).....	37
4.3.5	Parameter clear.....	38
4.3.6	Alarm history clear.....	39
<b>5</b>	PROTECTIVE FUNCTIONS.....	40
5.1	Causes and Corrective Actions.....	40

5.2 Correspondence Between Digital and Actual Characters .....	42
<b>6</b> SPECIFICATIONS .....	43
6.1 Brake Unit .....	43
6.2 Brake Resistor/Resistor Unit .....	43
<b>7</b> PRECAUTIONS FOR MAINTENANCE AND INSPECTION .....	44
7.1 Precautions for Maintenance and Inspection .....	44
7.2 Inspection Item .....	44
7.3 Periodic Inspection .....	45
7.4 Daily and Periodic Inspection .....	46
7.5 Replacement of Parts .....	47
<b>8</b> SELECTION .....	48
<b>9</b> OUTLINE DIMENSION DRAWINGS .....	51
<b>10</b> INSTRUCTIONS FOR UL, CSA STANDARD COMPLIANCE .....	56

MEMO



# 1 PRODUCT CHECKING AND PARTS IDENTIFICATION

- (1) Unpack the option unit and confirm that the product is as you ordered and intact.

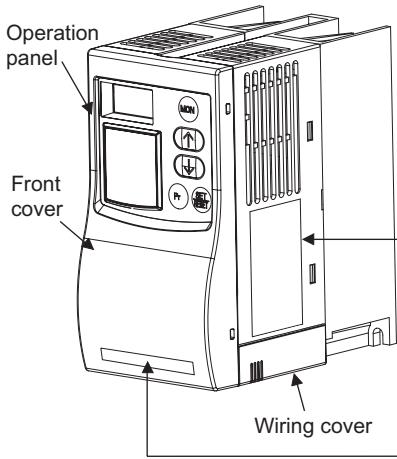

Rating plate

MITSUBISHI BRAKE UNIT

●MODEL FR-BU2-15K  
for 200V class INVERTER

SERIAL : XXXX  
MITSUBISHI ELECTRIC CORPORATION  
MADE IN JAPAN

MODEL FR-BU2- H   K

No.	Applied power supply voltage	Applied motor capacity (kW)
Not used	200V class	
H	400V class	

Capacity plate

FR-BU2-15K	XXXXXX
------------	--------

Brake unit type SERIAL number

- (2) Make sure that the package includes all accessories.

Brake unit (FR-BU2).....	1	Instruction manual .....	1
--------------------------	---	--------------------------	---

- Removal and reinstallation of the front cover  
Remove the front cover by pulling it toward you in the direction of arrow. To reinstall, match the cover to the brake unit front and install it straight.

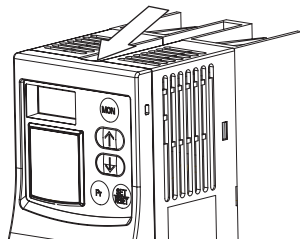

- Removal and reinstallation of the wiring cover  
The cover can be removed easily by pulling it toward you. To reinstall, fit the cover to the brake unit along the guides.

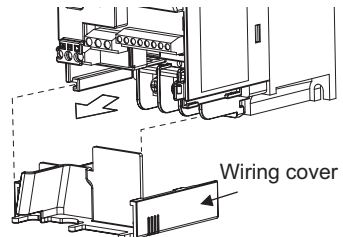



# 2 INSTALLATION

Enclosure surface mounting

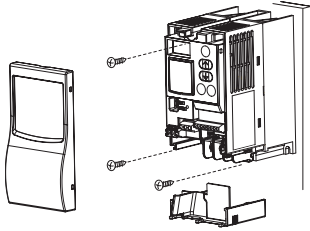

Remove the front cover and wiring cover to fix the brake unit to the surface.

Leave enough clearances as a cooling measure.

Encasing multiple brake units

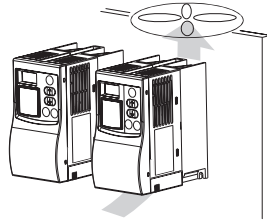

When encasing multiple brake units, install them in parallel as a cooling measure.

•Install the brake unit under the following conditions.

Vertical mounting

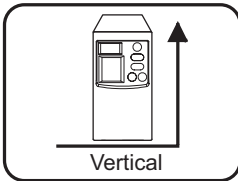

Ambient temperature and humidity

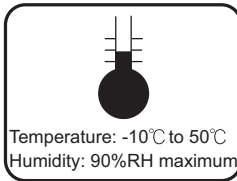



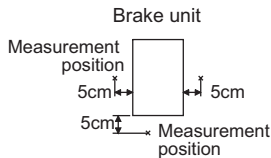
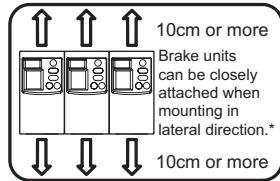





Clearances



\* Permissible ambient temperature is -10 °C to 40 °C when mounting brake units closely-attached. When ambient temperature exceeds 40 °C, clearances between brake units should be 1cm or more.

- The brake unit consists of precision mechanical and electronic parts. Never install or handle it in any of the following conditions as doing so could cause an operation fault or failure.

 Direct sunlight	 Vibration ( $5.9\text{m/s}^2$ or more)	 High temperature, high humidity	 Horizontal placement
 Vertical mounting (when mounting inside an enclosure)	 Transportation by holding the front cover	 Oil mist, flammable gas, corrosive gas, fluff, dust, etc.	 Mounting to combustible material

## CAUTION

**Mount the brake unit and resistor unit to incombustible material. Installing it to combustible materials directly or near combustible materials can cause a fire.**



# 3 WIRING

## 3.1 Terminals

### 3.1.1 Brake unit

Terminal Symbol		Terminal Name	Description	Rating	
Main circuit	P/+	Brake unit input terminal	Connect to the inverter terminal P and N.	—	
	N/-				
	PR*1	Resistor connection terminal	Connect the brake resistor.		
		Earth (Ground)	For earthing (grounding) the brake unit. Must be earthed (grounded).		
Control circuit	Contact input	BUE	Brake operation permission signal	Voltage at opening : 21 to 27VDC Controls by open collector output or no voltage contact signal.	
		RES	Reset input		Used to reset alarm output provided when protective circuit is activated. Turn on the RES signal for more than 0.1s, then turn it off.
		SD *3	Contact input common		Common terminal of the control input Brake transistor driving signal common (for master/slave operation, when connecting several brake units to one inverter in parallel, connect this signal to terminals of other brake units.)
	Master/slave signal	MSG *3	Brake transistor driving signal	Brake transistor driving signal terminal (For master/slave operation, when connecting several brake units to one inverter in parallel, connect this signal to terminals of other brake units.)	—

\*1 Only a brake resistor should be connected to terminal PR. Doing so may damage the brake unit.

\*2 BUE-SD is connected with a jumper in the initial status. Remove a jumper when using this signal. (When terminals are open, brake unit is not operated.)

\*3 Do not connect terminals SD, PC and MSG each other or to the ground. Doing so may damage the brake unit.

For sink logic (initial status), terminal SD acts as the common terminal of contact input. For source logic (initial status), terminal PC acts as the common terminal of contact input.

Terminal Symbol		Terminal Name	Description	Rating
Control circuit	PC *3		External transistor common, Contact input common (source)  When connecting the transistor output (open collector output), such as a programmable controller (PLC), connect the positive external power supply for transistor output to this terminal to prevent a malfunction caused by undesirable currents. When source logic has been selected, this terminal serves as a contact input common terminal.	—
	Relay output	A	Relay output 1 (Alarm output)  1 changeover contact output indicates that the brake unit protective function has activated. <ul style="list-style-type: none"> <li>• Normal  <ul style="list-style-type: none"> <li>Across B-C: Continuity</li> <li>Across A-C: Discontinuity</li> </ul> </li> <li>• Alarm  <ul style="list-style-type: none"> <li>Across B-C: Discontinuity</li> <li>Across A-C: Continuity</li> </ul> </li> </ul>	230VAC 0.3A 30VDC 0.3A
		B		
		C		

\*3 Do not connect terminals SD, PC and MSG each other or to the ground. Doing so may damage the brake unit.  
 For sink logic (initial status), terminal SD acts as the common terminal of contact input. For source logic (initial status), terminal PC acts as the common terminal of contact input.



- Terminal arrangement of the main circuit terminal

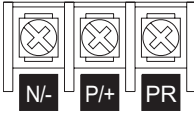

Cable size of the main circuit terminal

	Brake Unit Type	Main Circuit Terminal Screw Size	Crimping Terminal	Tightening Torque (N • m)	Cable Size		
					HIV cables, etc. (mm <sup>2</sup> )	AWG	PVC cables, etc. (mm <sup>2</sup> )
					N/- P/+, PR	N/- P/+, PR	N/- P/+, PR
200V	FR-BU2-1.5K/3.7K	M4	2-4	1.5	2	14	2.5
	FR-BU2-7.5K	M4	5.5-4	1.5	3.5	12	4
	FR-BU2-15K	M4	5.5-4	1.5	3.5	12	4
	FR-BU2-30K	M5	5.5-5	2.5	5.5	10	6
	FR-BU2-55K	M6	14-6	4.4	14	6	16
400V	FR-BU2-H7.5K	M4	2-4	1.5	2	14	2.5
	FR-BU2-H15K	M4	5.5-4	1.5	3.5	12	4
	FR-BU2-H30K	M4	5.5-4	1.5	3.5	12	4
	FR-BU2-H55K	M5	5.5-5	2.5	5.5	10	6
	FR-BU2-H75K	M6	14-6	4.4	14	6	16

• Control circuit terminal layout

Control circuit terminal block	<div style="text-align: center;"> <p>Jumper</p> </div> <p>Loosen the terminal screw and insert the cable into the terminal.</p> <p>☞ Screw size : M3</p> <p>☞ Tightening torque : 0.5N•m to 0.6N•m</p> <hr style="border: 1px solid black;"/> <p style="text-align: center;"><b>CAUTION</b></p> <hr style="border: 1px solid black;"/> <p><b>Undertightening can cause cable disconnection or malfunction. Overtightening can cause a short circuit or malfunction due to damage to the screw or unit.</b></p> <hr style="border: 1px solid black;"/> <p>☞ Cable size : 0.3mm<sup>2</sup> to 0.75mm<sup>2</sup></p> <p>☞ Screwdriver : Small ⊖ flat-blade screwdriver (Tip thickness : 0.4mm / tip width : 2.5mm)</p>	<p>Cable stripping size</p> <p style="text-align: center;">6mm</p> <p>Wire the stripped cable after twisting it to prevent it from becoming loose. In addition, do not solder it.*</p>
--------------------------------	---------------------------------------------------------------------------------------------------------------------------------------------------------------------------------------------------------------------------------------------------------------------------------------------------------------------------------------------------------------------------------------------------------------------------------------------------------------------------------------------------------------------------------------------------------------------------------------------------------------------------------------------------------------------------------------------------------------------------	----------------------------------------------------------------------------------------------------------------------------------------------------------------------------------------

\* Information on bar terminals

Introduced products (as of June, 2006) : Phoenix Contact Co.,Ltd.

Terminal Screw Size	Bar Terminal Model (with insulation sleeve)	Bar Terminal Model (without insulation sleeve)	Cable Size (mm <sup>2</sup> )
M3	AI 0.5-6WH	A 0.5-6	0.3 to 0.5
	AI 0.75-6GY	A 0.75-6	0.5 to 0.75

☞ Bar terminal crimping tool: CRIMPFOX ZA3 (Phoenix Contact Co., Ltd.)

---

**CAUTION**

---

**When using the bar terminal (without insulation sleeve), use care so that the twisted wires do not come out.**

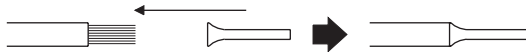



- Changing the control logic  
The input signals are set to sink logic when shipped from the factory.

To change the control logic, the jumper connector under the control panel must be moved to the other position.

- Change the jumper connector in the sink logic position to source logic position using tweezers, a pair of long-nose pliers etc. Change the jumper connector position before switching power on.

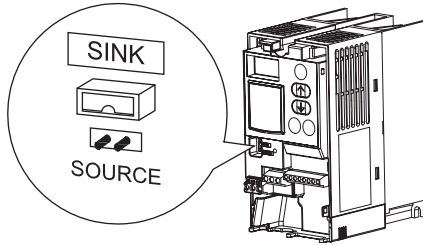

---

**CAUTION**

---

- Fully make sure that the front cover has been reinstalled securely.
  - The front cover is fitted with the capacity plate and the brake unit with the rating plate. Before reinstalling the front cover, check the serial numbers to ensure that the cover removed is reinstalled to the brake unit from where it was removed.
  - The sink-source logic change-over jumper connector must be fitted in only one of those positions. If it is fitted in both positions at the same time, the brake unit may be damaged.
-

**1) Sink logic type**

- In sink logic, a signal switches on when a current flows from the corresponding signal input terminal.  
Terminal SD is common to the contact input signals.

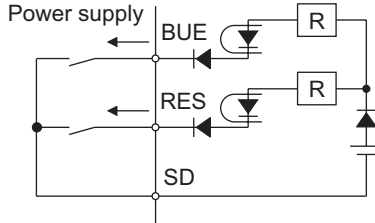

- Connecting a positive terminal of the external power supply for transistor output to terminal PC prevents a malfunction caused by undesirable currents. (Do not connect terminal SD of the brake unit with terminal 0V of the external power supply.)

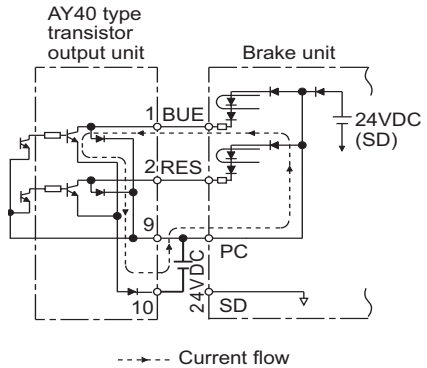



2) Source logic type

- In this logic, a signal switches on when a current flows into the corresponding signal input terminal.  
Terminal PC is common to the contact input signals.

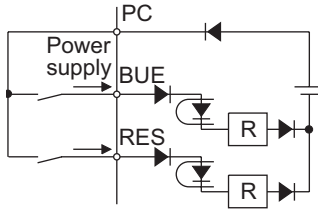

- Connecting a 0V terminal of the external power supply for transistor output to terminal SD prevents a malfunction caused by undesirable currents.

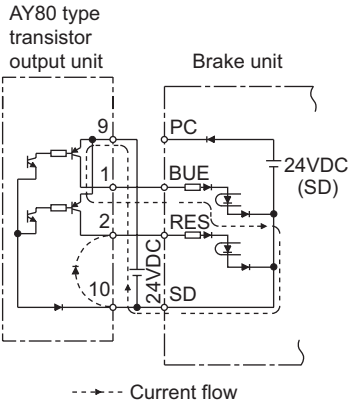

### 3.1.2 Resistor unit

#### (1) FR-BR-(H)

Terminal Symbol		Terminal Name	Description	Rating
Main circuit	P	Resistor unit input resistance	Connect to terminal P and PR of the brake unit.	—
	PR			
Control circuit	TH1	Alarm output terminal	Output signal indicates resistor overheat	1NC contact 110VAC, 5A 220VAC, 3A
	TH2			

- Terminal arrangement

Resistor unit input terminal

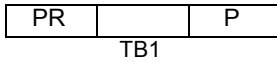

Control circuit terminal block arrangement

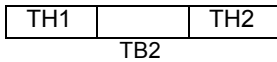

<FR-BR resistor unit>

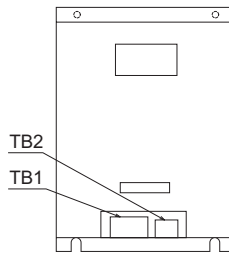

- Terminal screw size

Model		TB1	TB2
200V	FR-BR-15K	M4	M3
	FR-BR-30K	M5	M3
	FR-BR-55K	M6	M3
400V	FR-BR-H15K	M3	M3
	FR-BR-H30K	M4	M3
	FR-BR-H55K	M5	M3



(2) MT-BR5

Terminal Symbol		Terminal Name	Description	Rating
Main circuit	P	Resistor unit input terminal	Connect to terminal P and PR of the brake unit.	—
	PR			
	E	Earth terminal	For earthing (grounding) of the resistor unit. Must be earthed (grounded).	
Control circuit	TH1	Alarm output terminal	Output signal indicates resistor overheat.	1 NO contact, 110VAC, 5A 220VAC, 3A
	TH2			

• Terminal arrangement

Resistor unit input terminal

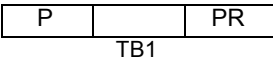

Control circuit terminal block arrangement

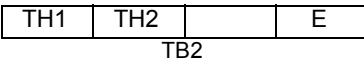

<MT-BR5 resistor unit>

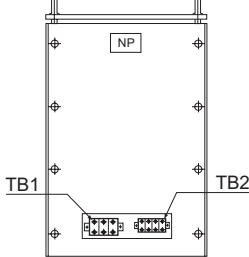

• Terminal screw size (MT-BR5)

Model	TB1	TB2
MT-BR5-55K	M6	M4
MT-BR5-H75K	M6	M4

### 3.2 Combinations of Brake Resistors for Brake Unit and Used Wires

Brake Unit Type	Brake Resistor, Resistor Unit Type	Cable Size (mm <sup>2</sup> )	
200V class	FR-BU2-1.5K	GZG 300W-50Ω (one)	2
	FR-BU2-3.7K	GRZG 200-10Ω (three in series)	2
	FR-BU2-7.5K	GRZG 300-5Ω (four in series)	3.5
	FR-BU2-15K	GRZG 400-2Ω (six in series)	3.5
		FR-BR-15K	
	FR-BU2-30K	FR-BR-30K	5.5
	FR-BU2-55K	FR-BR-55K	14
MT-BR5-55K			
400V class	FR-BU2-H7.5K	GRZG 200-10Ω (six in series)	2
	FR-BU2-H15K	GRZG 300-5Ω (eight in series)	3.5
		FR-BR-H15K	
	FR-BU2-H30K	GRZG 400-2Ω (twelve in series)	3.5
		FR-BR-H30K	
	FR-BU2-H55K	FR-BR-H55K	5.5
FR-BU2-H75K	MT-BR5-H75K	14	



### 3.3 External Connection Diagram

#### 3.3.1 Connection with the inverter

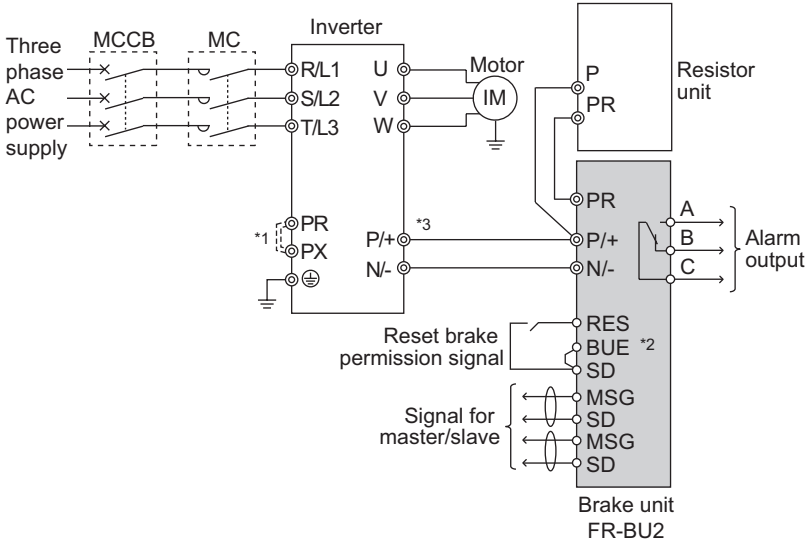

- \*1 When using the FR-BU2 with the FR-A500, A700 series 7.5K or less or FR-V500 series 5.5K or less, be sure to remove a jumper across terminal PR and PX.
- \*2 A jumper is connected across BUE and SD in the initial status.
- \*3 Do not remove a jumper across terminal P/+ and P1 except when connecting a DC reactor.

Connection method and parameter setting differ depending on the brake resistor and resistor unit to be used with.

Refer to the page below depending on the brake resistor and resistor unit to be used with and their application.

Brake Resistor, Resistor Unit	Application	Refer to Page	
		Wiring	Parameter setting
GRZG	Replacing the BU type brake unit	16 to 19	33
	Installation for the first time		Setting change is unnecessary
FR-BR-(H)	Replacing the FR-BU-(H) type brake unit	21 to 23	Setting change is unnecessary
	Installation for the first time		33
MT-BR5	Replacing the MT-BU5 type brake unit	24 to 26	33
	Installation for the first time		Setting change is unnecessary

Each mark appears in the following pages explains below.

- **GRZG** ....Section of the GRZG type brake resistor
- **FR-BR** ..Section of the FR-BR-(H) type resistor unit
- **MT-BR5** .Section of the MT-BR5 type resistor unit

## **CAUTION**

**Configure a protective circuit (shuts off power) corresponding to each brake resistor and resistor unit as in the table below to prevent overheat of the brake resistor and resistor unit to be combined.**

**Be sure to configure a sequence which detects overheat of a resistor to shut off power. If such circuit is not configured, it may result in resistor burnout, causing a fire.**

Brake Resistor, Resistor Unit	Resistor Overheat Detection	Refer to Page
GRZG	Configure a sequence which shuts off power when the brake unit outputs an alarm.	16 to 19
FR-BR-(H)	Configure a sequence which shuts off power without fail when a built-in thermal protector (NC contact) detects resistor overheat.	21 to 23
MT-BR5	Configure a sequence which shuts off power without fail when a built-in thermal protector (NO contact) detects resistor overheat.	24 to 26



### 3.4 Connection Example with the GRZG Type Brake

#### Resistor GRZG

Configure a sequence which shuts off power when the brake unit outputs an alarm to prevent burnout due to the temperature rise of the brake resistor in case the transistor inside the brake unit is damaged. In addition, it is recommended to configure a sequence which shuts off power in the input side by the external thermal relay connected to the brake resistor. The external connection diagram is shown below.

#### 3.4.1 When connecting one inverter and one brake unit GRZG

- External connection diagram 1

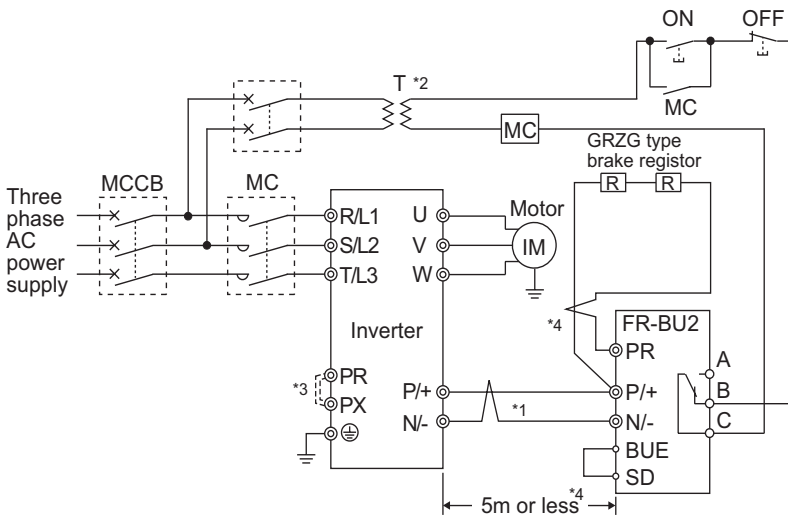

- \*1 Connect the inverter terminals (P/+, N/-) and brake unit (FR-BU2) terminals so that their terminal names match with each other. (Incorrect connection will damage the inverter and brake unit.) Do not remove a jumper across terminal P/+ and P1 except when connecting a DC reactor.
- \*2 When the power supply is 400V class, install a step-down transformer.
- \*3 When using the FR-BU2 with the FR-A500, A700 series inverter 7.5K or less or FR-V500 series inverter 5.5K or less, be sure to remove a jumper across terminal PR and PX.
- \*4 Keep a wiring distance of within 5m between the inverter, brake unit (FR-BU2) and brake resistor. Even when the wiring is twisted, the cable length must not exceed 10m.
- \*5 It is recommended to install an external thermal relay to prevent overheat of brake resistors. (Refer to page 17)

#### CAUTION

To replace the existing BU type brake unit, set "1" in Pr.0 Brake mode switchover. (Refer to page 33.)

- External connection diagram 2 (When connecting an external thermal relay)

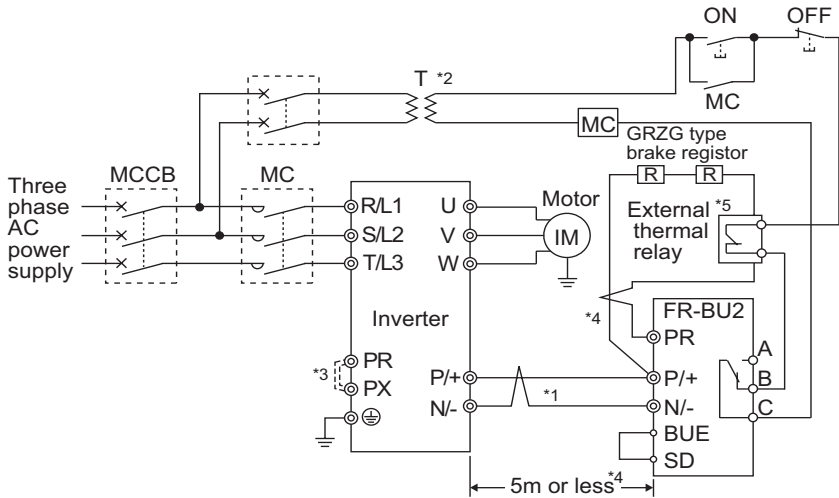

- \*1 Connect the inverter terminals (P/+, N/-) and brake unit (FR-BU2) terminals so that their terminal names match with each other. (Incorrect connection will damage the inverter and brake unit.) Do not remove a jumper across terminal P/+ and P1 except when connecting a DC reactor.
- \*2 When the power supply is 400V class, install a step-down transformer.
- \*3 When using the FR-BU2 with the FR-A500, A700 series inverter 7.5K or less or FR-V500 series inverter 5.5K or less, be sure to remove a jumper across terminal PR and PX.
- \*4 Keep a wiring distance of within 5m between the inverter, brake unit (FR-BU2) and brake resistor. Even when the wiring is twisted, the cable length must not exceed 10m.
- \*5 It is recommended to install an external thermal relay to prevent overheat of brake resistors.

### <Recommended external thermal relay>

Brake Unit	Brake Resistor	Recommended External Thermal Relay
FR-BU2-1.5K	GZG 300W-50Ω	TH-N20 1.3A
FR-BU2-3.7K	GRZG 200-10Ω	TH-N20 3.6A
FR-BU2-7.5K	GRZG 300-5Ω	TH-N20 6.6A
FR-BU2-15K	GRZG 400-2Ω	TH-N20 11A
FR-BU2-H7.5K	GRZG 200-10Ω	TH-N20 3.4A
FR-BU2-H15K	GRZG 300-5Ω	TH-N20 6.6A
FR-BU2-H30K	GRZG 400-2Ω	TH-N20 11A

### CAUTION

To replace the existing BU type brake unit, set "1" in Pr.0 Brake mode switchover. (Refer to page 33.)



### 3.4.2 When connecting several brake units to one inverter GRZG

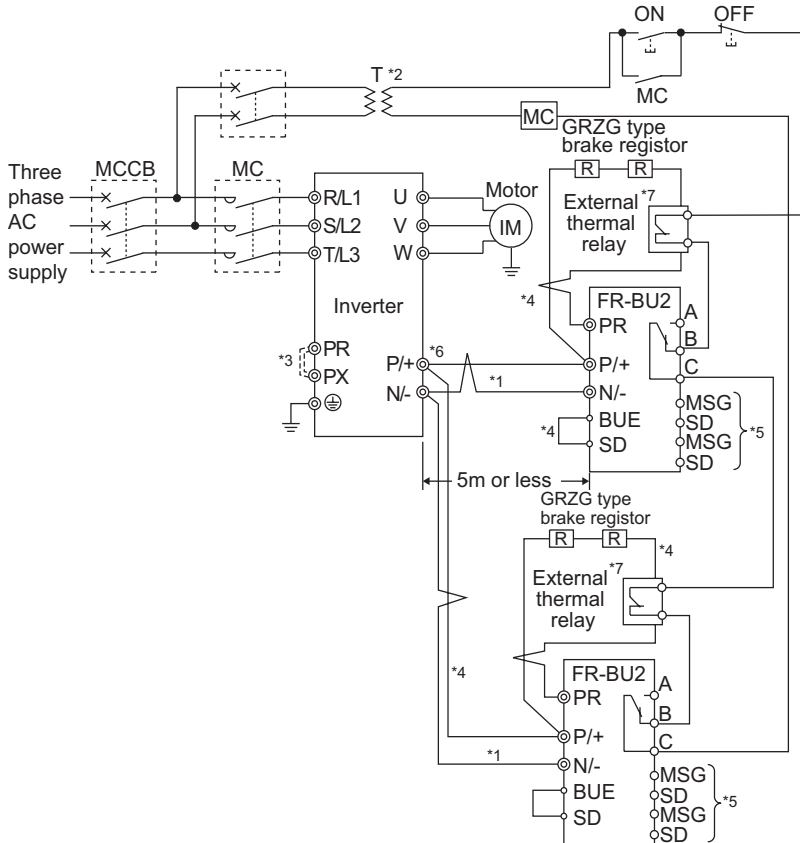

- \*1 Connect the inverter terminals (P/+, N/-) and brake unit (FR-BU2) terminals so that their terminal names match with each other. (Incorrect connection will damage the inverter and brake unit.) Do not remove a jumper across terminal P/+ and P1 except when connecting a DC reactor.
- \*2 When the power supply is 400V class, install a step-down transformer.
- \*3 When using the FR-BU2 with the FR-A500, A700 series inverter 7.5K or less or FR-V500 series inverter 5.5K or less, be sure to remove a jumper across terminal PR and PX.
- \*4 The wiring distance between the inverter, brake unit (FR-BU2) and brake resistor should be within 5m. Even when the wiring is twisted, the cable length must not exceed 10m.
- \*5 When connecting several brake units to one inverter, always connect the master/slave operation wiring on *page 19* in addition to the above connection.
- \*6 When connecting several FR-BU2 to one inverter, connect P/+ of each FR-BU2 and of the inverter and N/- respectively. Do not pass wires from terminal P/+ and N/- of the FR-BU2 to terminals of other FR-BU2.
- \*7 It is recommended to install an external thermal relay to prevent overheat of brake resistors. (*Refer to page 17*)

## CAUTION

**Do not run the BU type brake unit and FR-BU2 in parallel. Doing so could cause an alarm or brake unit failure. Use the FR-BU2 only when performing parallel operation.**

### 3.4.3 Master/slave operation when connecting several brake units GRZG

Parallel operation by master ↔ slave operation (10 units maximum)

When several units are connected, make sure to connect a signal cable to terminals (MSG, SD) for master/slave to operate.

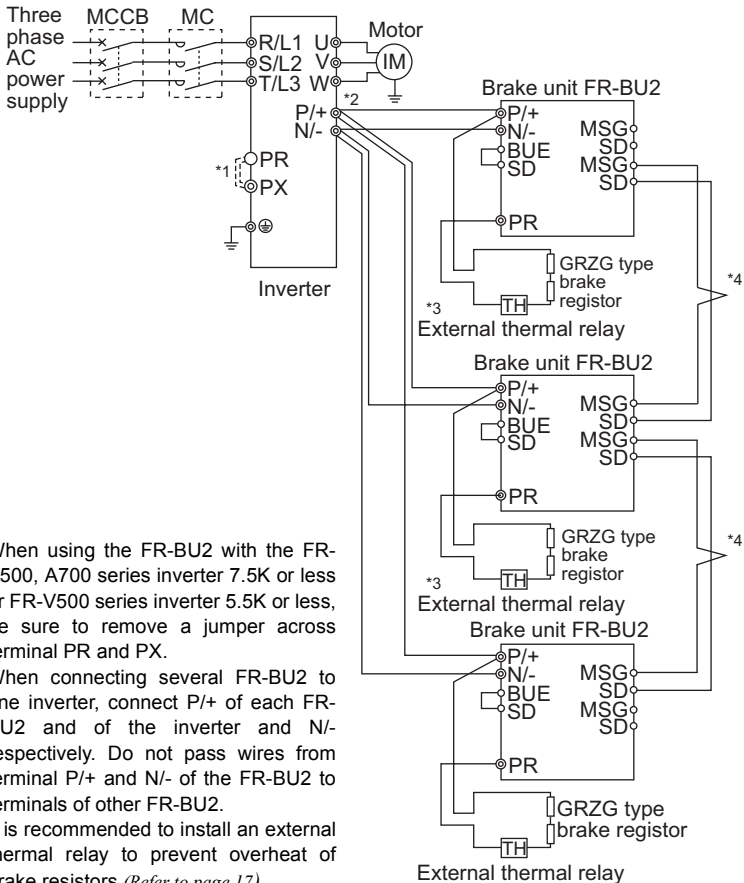

- \*1 When using the FR-BU2 with the FR-A500, A700 series inverter 7.5K or less or FR-V500 series inverter 5.5K or less, be sure to remove a jumper across terminal PR and PX.
- \*2 When connecting several FR-BU2 to one inverter, connect P/+ of each FR-BU2 and of the inverter and N/- respectively. Do not pass wires from terminal P/+ and N/- of the FR-BU2 to terminals of other FR-BU2.
- \*3 It is recommended to install an external thermal relay to prevent overheat of brake resistors. (Refer to page 17)
- \*4 The wiring length of the terminal MSG and SD should be 10m maximum. In addition, twist five times or more per 1m.



---

---

**CAUTION**

---

---

- To emphasize connection of master/slave operation in this diagram, other connections are not shown. When actually connecting units, configure a circuit which prevents resistor overheat as shown in a connection example "When connecting several brake units to one inverter" on page 18.
  - To replace the existing BU type brake unit, set "1" in *Pr.0 Brake mode switchover*. (Refer to page 33)
  - Do not run the BU type brake unit and FR-BU2 in parallel. Doing so could cause an alarm or brake unit failure. Use the FR-BU2 only when performing parallel operation.
- 
-

### 3.5 FR-BR-(H) Connection Example with Resistor Unit

FR-BR

Make up a sequence which always shuts off power in the input side by an overheat signal of the built-in thermal relay of the resistor unit in case a built-in transistor of the brake unit is damaged and configure a circuit which prevents the brake resistor from abnormal overheating, leading to burnout. The external connection diagram is shown below.

#### 3.5.1 When connecting one inverter and one brake unit FR-BR

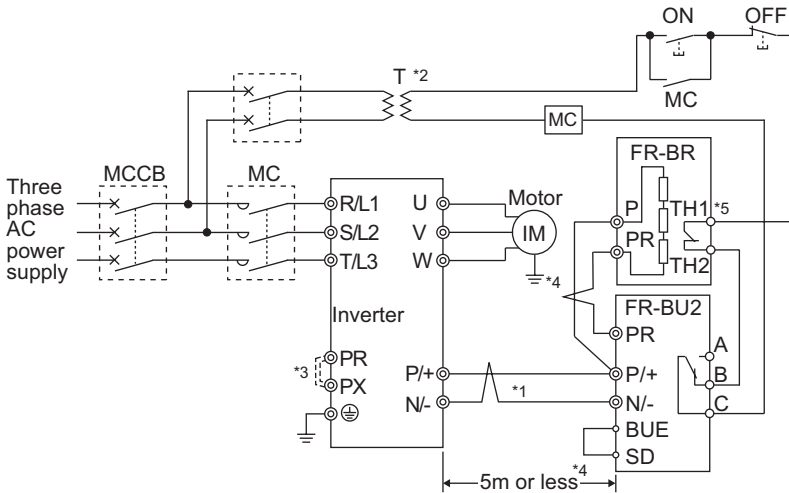

- \*1 Connect the inverter terminals (P/+, N/-) and brake unit (FR-BU2) terminals so that their terminal names match with each other. (Incorrect connection will damage the inverter and brake unit.)  
Do not remove a jumper across terminal P/+ and P1 except when connecting a DC reactor.
- \*2 When the power supply is 400V class, install a step-down transformer.
- \*3 When using the FR-BU2 with the FR-A500, A700 series inverter 7.5K or less or FR-V500 series inverter 5.5K or less, be sure to remove a jumper across terminal PR and PX.
- \*4 The wiring distance between the inverter, brake unit (FR-BU) and resistor unit (FR-BR) should be within 5m. Even when the wiring is twisted, the cable length must not exceed 10m.
- \*5 Normal: across TH1-TH2...close, Alarm: across TH1-TH2...open



### 3.5.2 When connecting several brake units to one inverter FR-BR

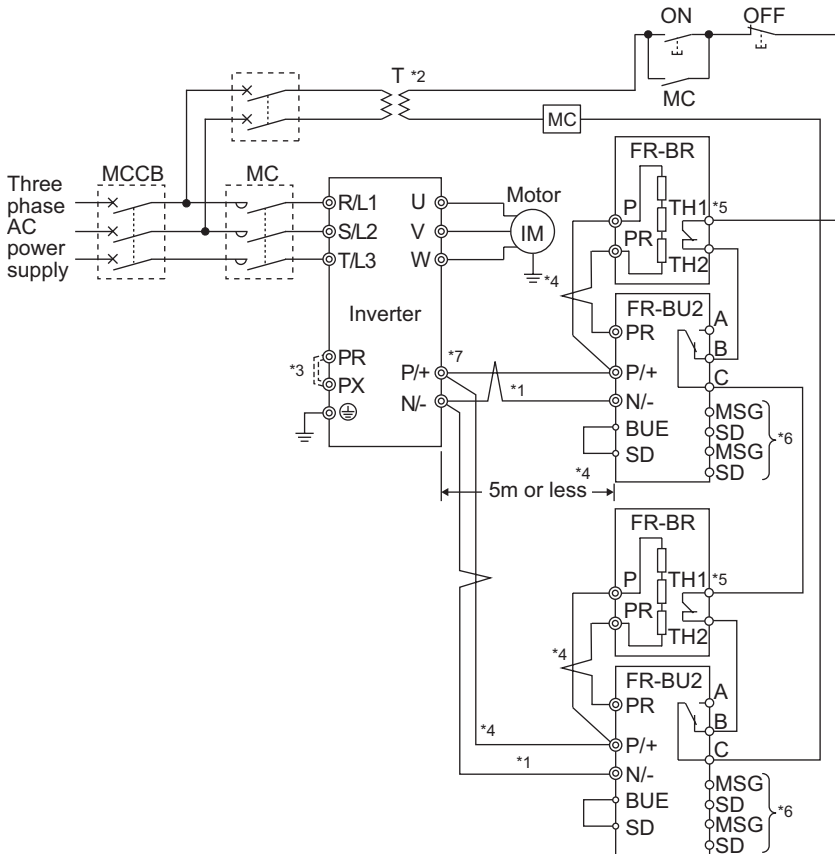

- \*1 Connect the inverter terminals (P/+, N/-) and brake unit (FR-BU2) terminals so that their terminal names match with each other. (Incorrect connection will damage the inverter and brake unit.)  
Do not remove a jumper across terminal P/+ and P1 except when connecting a DC reactor.
- \*2 When the power supply is 400V class, install a step-down transformer.
- \*3 When using the FR-BU2 with the FR-A500, A700 series inverter 7.5K or less or FR-V500 series inverter 5.5K or less, be sure to remove a jumper across terminal PR and PX.
- \*4 The wiring distance between the inverter, brake unit (FR-BU) and resistor unit (FR-BR) should be within 5m. Even when the wiring is twisted, the cable length must not exceed 10m.
- \*5 Normal: across TH1-TH2...close, Alarm: across TH1-TH2...open
- \*6 When connecting several brake units to one inverter, always connect the master/slave operation wiring on *page 23* in addition to the above connection.
- \*7 When connecting several FR-BU2 to one inverter, connect P/+ of each FR-BU2 and of the inverter and N/- respectively. Do not pass wires from terminal P/+ and N/- of the FR-BU2 to terminals of other FR-BU2.

### 3.5.3 Master/slave operation when connecting several brake units FR-BR

Parallel operation by master ⇔ slave operation (10 units maximum)

When several units are connected, make sure to connect a signal cable to terminals (MSG, SD) for master/slave to operate.

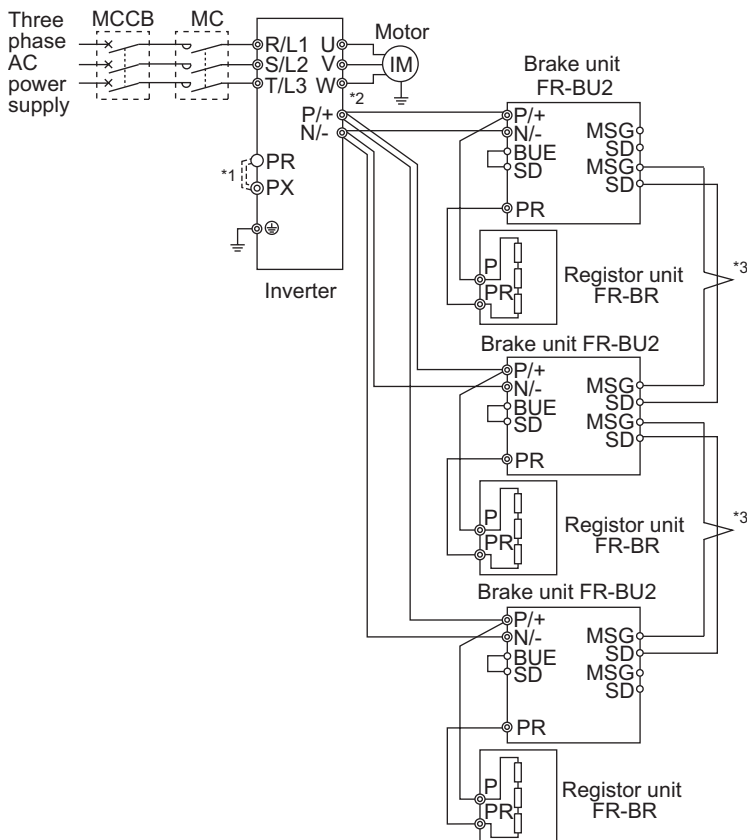

\*1 When using the FR-BU2 with the FR-A500, A700 series inverter 7.5K or less or FR-V500 series inverter 5.5K or less, be sure to remove a jumper across terminal PR and PX.

\*2 When connecting several FR-BU2 to one inverter, connect P/+ of each FR-BU2 and of the inverter and N/- respectively. Do not pass wires from terminal P/+ and N/- of the FR-BU2 to terminals of other FR-BU2.

\*3 The wiring length of the terminal MSG and SD should be 10m maximum. In addition, twist five times or more per 1m.

#### CAUTION

**To emphasize connection of master/slave operation in this diagram, other connections are not shown. When actually connecting units, configure a circuit which prevents resistor overheat as shown in a connection example "When connecting several brake units to one inverter" on page 22.**



### 3.6 Connection Example with MT-BR5 Type Resistor

#### Unit MT-BR5

Make up a sequence which always shuts off power in the input side by an overheat signal of the built-in thermal relay of the resistor unit in case a built-in transistor of the brake unit is damaged and configure a circuit which prevents abnormal overheat of the brake resistor leading to burnout. The external connection diagram is shown below.

#### 3.6.1 When connecting one inverter and one brake unit MT-BR5

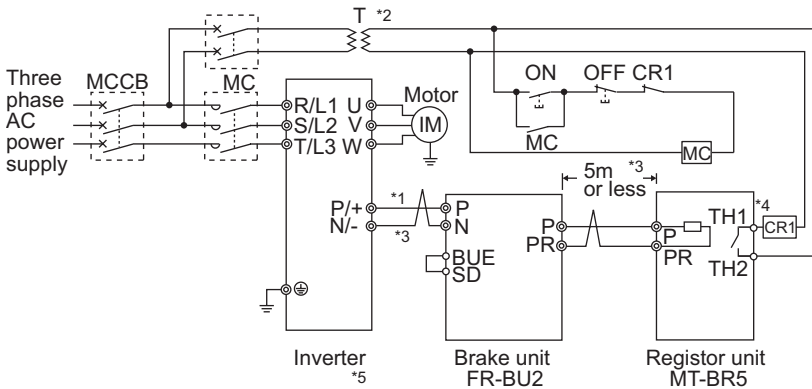

- \*1 Connect the inverter terminals (P/+, N/-) and brake unit (FR-BU2) terminals so that their terminal names match with each other. (Incorrect connection will damage the inverter and brake unit.)  
Do not remove a jumper across terminal P/+ and P1 except when connecting a DC reactor.
- \*2 When the power supply is 400V class, install a step-down transformer.
- \*3 The wiring distance between the inverter, brake unit (FR-BU2) and resistor unit (MT-BR5) should be within 5m. If twisted wires are used, the distance should be within 10m.
- \*4 Normal: across TH1-TH2...open, Alarm: across TH1-TH2...close
- \*5 CN8 connector used with the MT-BU5 type brake unit is not used.

#### CAUTION

**When replacing from the existing MT-BU5 type brake unit, set "2" in Pr:0 Brake mode switchover (refer to page 33) , "1" in Pr:30 Regenerative function selection and "10%" in Pr:70 Special regeneration brake duty (refer to the inverter manual) of the inverter.**

### 3.6.2 When connecting several brake units to one inverter MT-BR5

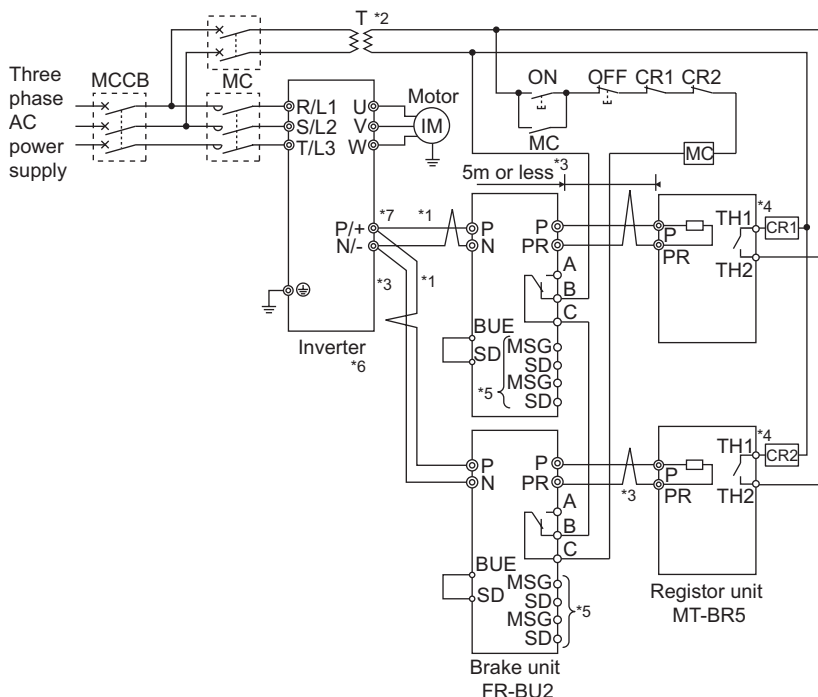

- \*1 Connect the inverter terminals (P/+, N/-) and brake unit (FR-BU2) terminals so that their terminal names match with each other. (Incorrect connection will damage the inverter and brake unit.)  
Do not remove a jumper across terminal P/+ and P1 except when connecting a DC reactor.
- \*2 When the power supply is 400V class, install a step-down transformer.
- \*3 The wiring distance between the inverter, brake unit (FR-BU2) and resistor unit (MT-BR5) should be within 5m. Even when the wiring is twisted, the cable length must not exceed 10m.  
Normal: across TH1-TH2...open, Alarm: across TH1-TH2...close
- \*4 When connecting several brake units to one inverter, always connect the master/slave operation wiring on *page 26* in addition to the above connection.
- \*5 CN8 connector used with the MT-BU5 type brake unit is not used.
- \*7 When connecting several FR-BU2 to one inverter, connect P/+ of each FR-BU2 and of the inverter and N/- respectively. Do not pass wires from terminal P/+ and N/- of the FR-BU2 to terminals of other FR-BU2.

#### CAUTION

- **When replacing from the existing MT-BU5 type brake unit, set "2" in Pr:0 Brake mode switchover (refer to page 33) , "1" in Pr:30 Regenerative function selection and "10%" in Pr:70 Special regeneration brake duty (refer to the inverter manual) of the inverter.**
- **Do not operate the MT-BU5 type brake unit and FR-BU2 in parallel. Doing so could cause an alarm or brake unit failure. Use the FR-BU2 only when performing parallel operation.**



### 3.6.3 Master/slave operation when connecting several brake units MT-BR5

Parallel operation by master ↔ slave operation (10 units maximum)

When several units are connected, make sure to connect a signal cable to terminals (MSG, SD) for master/slave to operate.

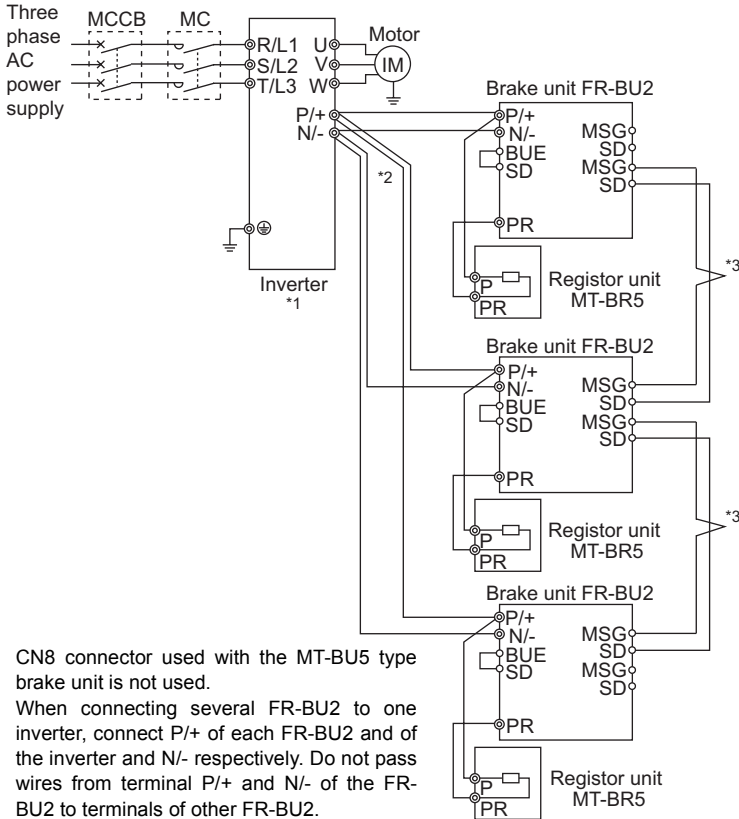

- \*1 CN8 connector used with the MT-BU5 type brake unit is not used.
- \*2 When connecting several FR-BU2 to one inverter, connect P/+ of each FR-BU2 and of the inverter and N/- respectively. Do not pass wires from terminal P/+ and N/- of the FR-BU2 to terminals of other FR-BU2.
- \*3 The wiring length of the terminal MSG and SD should be 10m maximum. In addition, twist five times or more per 1m.

---

---

**CAUTION**

---

---

- To emphasize connection of master/slave operation in this diagram, other connections are not shown. When actually connecting units, configure a circuit which prevents resistor overheat as shown in a connection example "When connecting several brake units to one inverter" on page 25 .
  - When replacing from the existing MT-BU5 type brake unit, set "2" in *Pr.0 Brake mode switchover* (refer to page 33) , "1" in *Pr.30 Regenerative function selection* and "10%" in *Pr.70 Special regeneration brake duty* (refer to the inverter manual) of the inverter.
  - Do not run the MT-BU5 type brake unit and FR-BU2 in parallel. Doing so could cause an alarm or brake unit failure. Use the FR-BU2 only when performing parallel operation.
- 
-



### 3.7 Wiring Instructions

- (1) When using this brake unit with the FR-A500, A700 series inverter 7.5K or less or FR-V500 series inverter 5.5K or less, be sure to remove a jumper across terminal PR and PX.  
(A failure to do so may damage a built-in brake resistor.)
- (2) Correctly connect the terminals P/+, N/- of the brake unit and terminals P, N of the inverter.

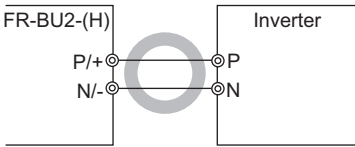

Correct connection

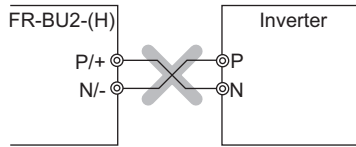

Wrong connection

- (3) Minimize the cable length between the inverter and brake unit and the resistor unit and brake unit. In addition, twist five times or more per 1m. (Use a twisted cable when the wiring length exceeds 5m. Even when the wiring is twisted, the cable length must not exceed 10m.)

The brake unit may be damaged if cables are not twisted when the wiring length is 5m or more or the wiring length exceeds 10m or more even if cables are twisted.

Use the wires of the above recommended size or larger (*refer to page 6*).

The difference color cables twisted is recommended to prevent miswiring.

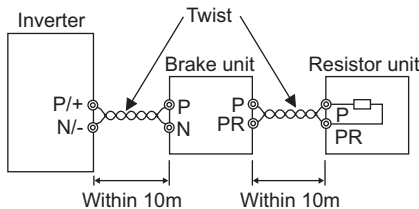

- (4) Do not allow wire offcuts to enter the unit, e.g. cover the vent hole at the top during wiring operation.

- (5) When connecting the FR-BEL power factor improving DC reactor, the brake unit terminal P/+ must be connected to the inverter. Accidental connection to P1 terminal may damage the brake unit.

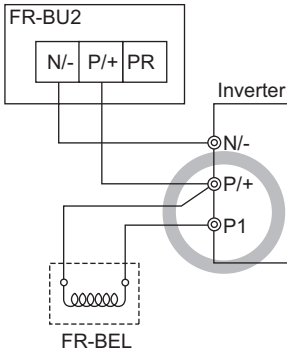

Correct connection

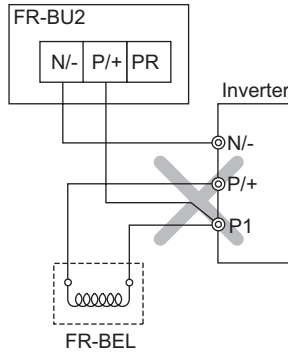

Wrong connection

- (6) When connecting several FR-BU2 to the inverter, be sure to connect terminal P/+, N/- of the brake unit to terminal P/+, N/- of the inverter. Do not pass wires from terminal P/+ and N/- of the brake unit to terminals of other brake unit.

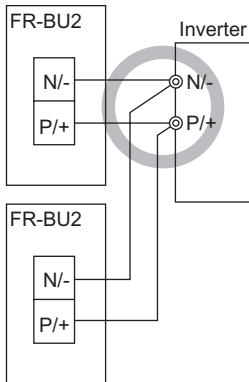

Correct connection

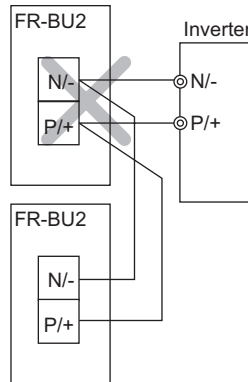

Wrong connection



# 4 OPERATION

## 4.1 Control Panel

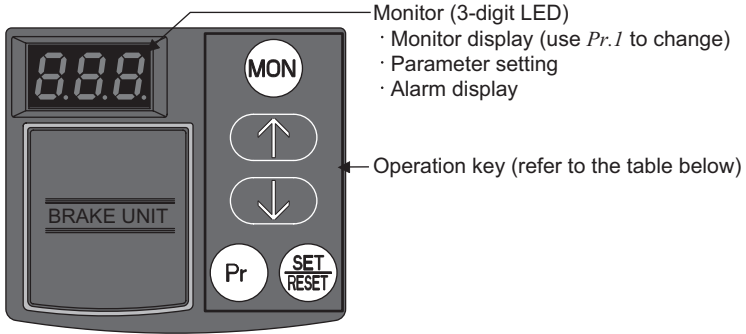

Key	Description
	Use this key to switch between the monitor display and alarm history display.
 	<ul style="list-style-type: none"> <li>•Changes parameter number and setting value.</li> <li>•Changes the alarm history display.</li> </ul>
	Switches to the parameter setting mode and a parameter setting screen appears.
	Use for parameter setting and alarm reset.

## 4.2 Basic Operation

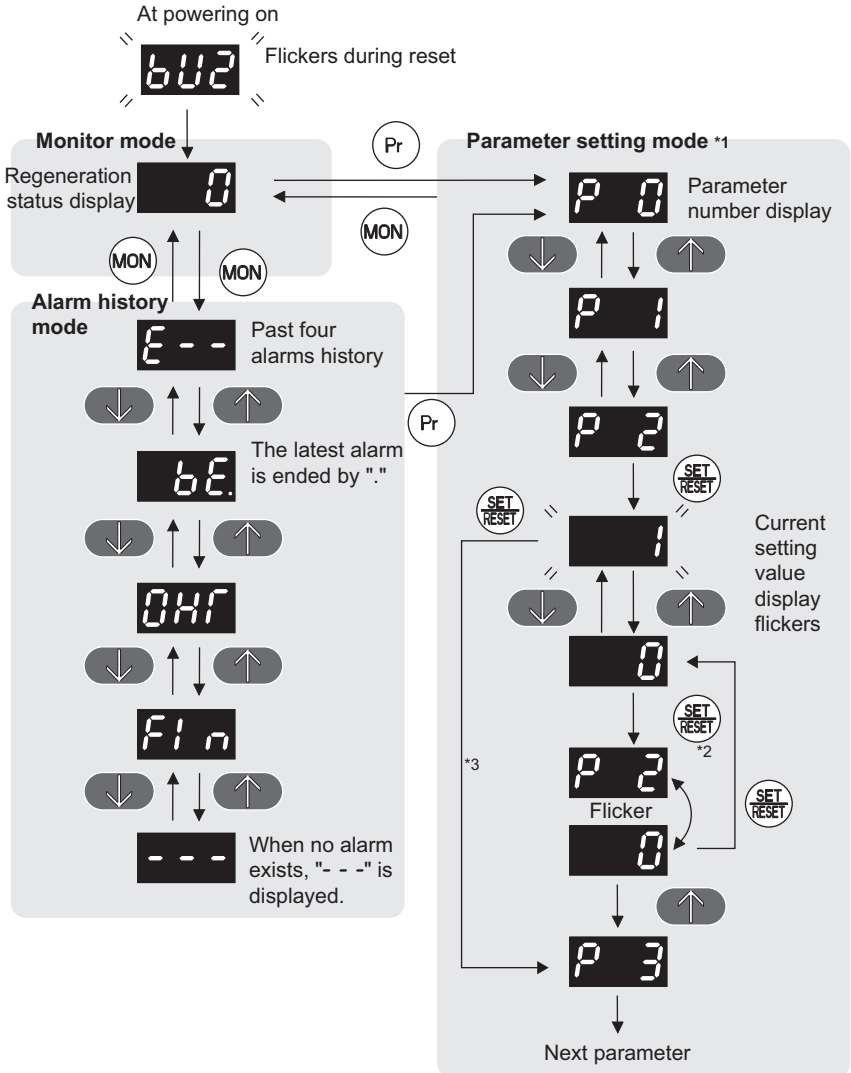

- \*1 Pressing (Pr) in the parameter setting mode displays parameter number.
- \*2 When the written value differs from the current setting value, write is performed.
- \*3 When the written value is the same as the current setting value, next parameter number is displayed.



### 4.3 Parameter List

Parameter	Name	Minimum Setting Increments	Initial Value	Setting Range	Reference Page
0*	Brake mode switchover	1	0	0 to 2	33
1	Monitor display data selection	1	0	0 to 5	34
2*	Input terminal function selection 1 (RES)	1	0	0 to 3	36
3*	Input terminal function selection 2 (BUE)	1	1		
77	Parameter write selection	1	0	0, 1	37
78	Cumulative energization time carrying-over times	1	0	0 to 999 (reading only)	34
CLr	Parameter clear	1	0	0, 1	38
ECL	Alarm history clear	1	0	0, 1	39
C1	Parameter for manufacturer setting. Do not set.				

\* Set this parameter only when the inverter is at a stop.

### 4.3.1 Mode switchover (Pr.0)

Change the setting when replacing the BU type brake unit and MT-BU5 brake unit. When replacing the FR-BU type brake unit or using with the GRZG type brake resistor, FR-BR-(H) resistor unit or MT-BR5 type resistor unit for the first time, use this parameter with initial value "0" set.

Parameter Number	Name	Initial Value	Setting Range	Description
0	Brake mode switchover	0	0	FR-BU2 mode
			1 *1	BU mode
			2 *2	MT-BU5 mode

\*1 Available with the FR-BU2-1.5K to 15K and FR-BU2-H7.5K to H30K only.

\*2 Available with the FR-BU2-55K and FR-BU2-H75K only.

\*3 Perform the above parameter setting only when the inverter is at a stop.

#### (1) FR-BU2 mode (setting value "0" (initial value))

Set this value when replacing the FR-BU type brake unit or using with the GRZG type brake resistor, FR-BR-(H) type resistor unit or MT-BR5 type resistor unit for the first time.

#### (2) BU mode (setting "1")

Set this value when replacing the existing BU type brake unit.

- Connecting the GRZG type brake resistor provides the same braking capability with the BU type brake unit.
- Available with the FR-BU2-1.5K to 15K and FR-BU2-H7.5K to H30K only.

#### (3) MT-BU5 mode (setting "2")

Set this value when replacing the existing MT-BU5 type brake unit.

- Connecting the MT-BU5 type resistor unit provides the same braking capability as the MT-BU5.
- Available with the FR-BU2-55K and FR-BU2-H75K only.

### REMARKS

Refer to *page 13* for combination of the brake resistor and resistor unit.



### 4.3.2 Multi-function monitor display (Pr.1, Pr.78)

Select the monitor to be displayed on the operation panel.

Parameter Number	Name	Initial Value	Setting Range	Description	Remarks
1	Monitor display data selection	0	0*	Regeneration status display	
			1	DC bus voltage (V)	
			2	DC bus voltage peak value (V)	
			3	Cumulative energization time (100h)	Energization time from shipment of the brake unit is accumulated every one hour. Time is not accumulated if power is turned off within one hour.
			4	Regenerative brake duty(%ED)(%)	Indicates the brake duty in %. The amount of thermal heat is displayed in the BU mode (Pr.0="1").
			5	Regenerative brake duty peak value (%)	
78	Cumulative energization time carrying-over times	0	0 to 999 (Reading only)	The numbers of cumulative energization time monitor exceeded 65535h is displayed. (Reading only)	

\* When Pr.1="0"(initial value), the third digit (far left) of the 3-digit LED display indicates regeneration status. Two segments flicker (rotate) at a time during regeneration as shown below and rotate quickly when regeneration amount is large.

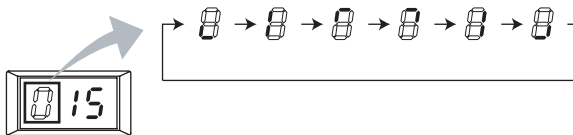

**(1) Monitor description list (Pr. 1)**

<i>Pr.1</i> setting	Monitor item	Increments	Description
0	Regeneration status display	1%	Indicates the ratio of brake unit operation during the specified time
1	DC bus voltage	1V	DC bus voltage is displayed.
2	DC current voltage peak value	1V	Holds the peak value of the DC bus voltage monitor ( <i>Pr.1</i> = "1"). (clears at every inverter power on)
3	Cumulative energization time	100h	Accumulated energization time (power on time) after shipment of the brake unit is displayed. Energization time is stored in EEPROM every one hour. However, the displayed increments is 100h and "100h" is indicated as "1" and "200h" as "2". The value is cleared to 0h when the accumulated value exceeds 65535h and one count is added to <i>Pr.78</i> . (up to "655" is displayed on the panel)
4	Regenerative brake duty (%ED)	0.1%	Heat amount currently accumulated is displayed in % as brake duty. A value less than 0.1% is rounded up to display. <ul style="list-style-type: none"> <li>FR-BU2 mode (<i>Pr.0</i> = "0" (initial value)) MT-BU5 mode (<i>Pr.0</i> = "2")</li> </ul> If the brake duty exceeds 10%, regenerative brake is not operated. When the brake duty has fallen to or below 10%, brake operation starts. <ul style="list-style-type: none"> <li>BU mode (<i>Pr.0</i> = "1")</li> </ul> Thermal heat cumulative value is displayed. A value less than 1 is rounded up to display. (Thermal alarm ( <i>THE</i> ) is activated when the value reaches 100%.)
5	Regenerative brake duty peak value	0.1%	Holds the peak value of the regenerative brake duty (%ED) monitor ( <i>Pr.1</i> = "4"). A value less than 0.1% is rounded up to display. Clamped at 100%. A peak value since power on is held and cleared at every reset. The amount of thermal heat peak value is displayed in the BU mode ( <i>Pr.0</i> = "1"). Clamped at 100%.

**(2) Cumulative energization time carrying-over time (*Pr.1* = "3", *Pr.78* )**

- Cumulative energization time monitor (*Pr.1* = "3") accumulates energization time from shipment of the brake unit every one hour.  
Time is not accumulated if power is turned off within one hour.
- If the cumulative value exceeds 65535h (monitor display is up to "655"), it is added up from 0. Use *Pr.78* to check the number of cumulative energization time monitor exceeded "655".



### 4.3.3 Input terminal function selection (Pr.2, Pr.3)

Use these parameters to select/change the input terminal functions.

Parameter Number	Name	Initial Value	Setting Range	Description
2	Input terminal function selection 1 (RES)	0	0 to 3	Refer to the following table
3	Input terminal function selection 2 (BUE)*1	1		

\*1 A jumper is connected across terminal RES and SD in the initial setting.

\*2 Perform the above parameter setting only when the inverter is at a stop.

#### Relationship between the setting value and terminal function

Setting	Signal	Function	Description
0	RES	Brake unit reset	Used to reset alarm output provided when protective circuit is activated. Turn on the RES signal for more than 0.1s, then turn it off. (Reset operation is made both at a normal operation and an alarm.)
1	BUE*	Brake operation permission signal	Input operation permission signal from outside. Turning off the signal shuts off power and turning on the signal allows brake operation. When other regeneration units such as a power regeneration converter are installed, use this signal to allow or limit operation of the brake unit.
2	OHB	Brake resistor overheating (NC contact)	Input contact when using an external thermal relay to protect resistor from overheating, etc. Turning off the signal results in resistor overheating alarm (OHT). Available when the FR-BR is connected.
3	OHA	Brake resistor overheating (NO contact)	Input contact when using an external thermal relay to protect resistor from overheating, etc. Turning on the signal results in resistor overheating alarm (OHT). Available when the MT-BR5 is connected.

\* If BUE signal (brake operation enable) is not assigned, brake operation is always allowed.

#### 4.3.4 Parameter write disable selection (Pr. 77)

You can select whether write to various parameters can be performed or not. Use this function to prevent parameter values from being rewritten by misoperation.

Parameter Number	Name	Initial Value	Setting Range	Description
77	Parameter write selection	0	0	Parameter write is always enabled.
			1	Parameter write is not enabled.

##### (1) Disable parameter write (setting "1")

- Parameter write is not enabled. (Read is enabled.)
- Parameter clear cannot be performed, either.



### 4.3.5 Parameter clear

**POINT**

- **Set "1" in CLr All parameter clear to initialize all parameters. Parameters are not cleared when "1" is set in Pr. 77 Parameter write selection .**

Operation		Display
1. Screen at powering on The mode is changed to monitor mode.	⇒	
2. Press (Pr) to choose the parameter setting mode.	(Pr) ⇒	( The parameter number read previously appears. )
3. Press (↑) Press (↓) until CLr (Parameter clear) appears.	(↑) (↓) ⇒	
4. Press (SET/RESET) to read the currently set value. "0" (initial value) appears.	(SET/RESET) ⇒	
5. Press (↑) Press (↓) to change it to the set value "1".	(↑) (↓) ⇒	
6. Press (SET/RESET) to set.	(SET/RESET) ⇒	

**Flicker...parameter clear complete!!**

- Press (↑) Press (↓) to read another parameter.
- Press (SET/RESET) to show the setting again.

**CAUTION**

*Pr.78 Cumulative energization time carrying-over times is not cleared.*

### 4.3.6 Alarm history clear

**POINT**

Set "1" in *ECL Alarm history clear* to clear alarm history.

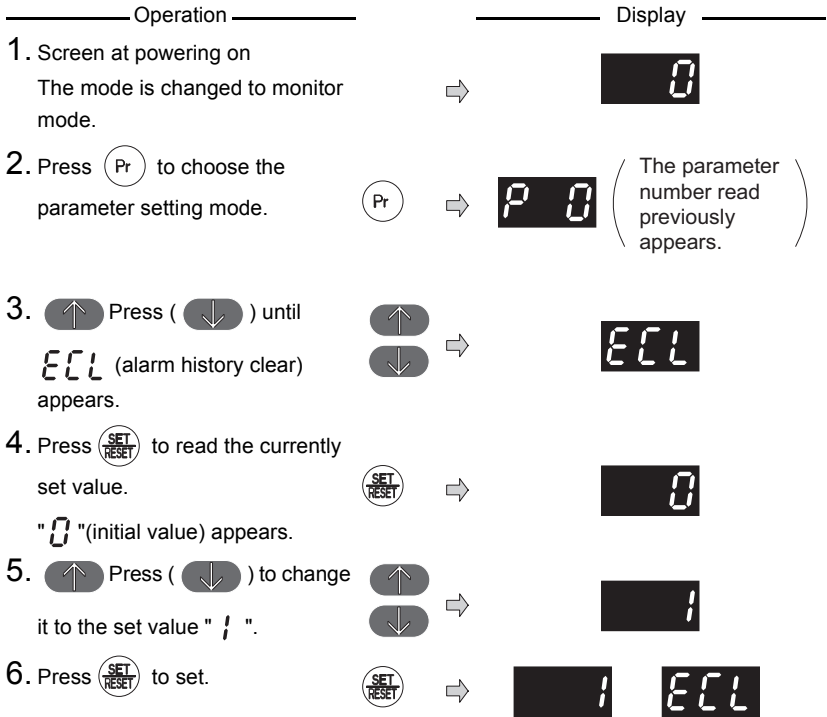

Flicker...Alarm history clear complete!!

- Press ( ) to read another parameter.
- Press ( ) to show the setting again.

**REMARKS**

Refer to page 31 for checking alarm history.



# 5 PROTECTIVE FUNCTIONS

## 5.1 Causes and Corrective Actions

• Error Message

A message regarding operational troubles is displayed. Output is not shutdown.

Operation panel indication	Er1	Er1
Name	Write disable error	
Description	You attempted to make parameter setting when Pr. 77 Parameter write selection has been set to disable parameter write.	
Check point	Check the setting of Pr. 77 Parameter write selection. (Refer to page 37)	

Operation panel indication	Er2	Er2
Name	Outside range error	
Description	When a value outside the parameter setting range is written	
Check point	Check the parameter setting value.	
Corrective action	Input a setting value within the parameter setting range.	

• Major faults

When the protective function is activated, the inverter output is shut-off and an alarm output is provided.

Operation panel indication	THE	THE
Name	Thermal error *1 , *2	
Description	The electronic thermal relay function built in the brake unit detects brake resistor overheat and the protection circuit is activated to stop the brake operation when the temperature reaches the specified value.	
Check point	Check that the regeneration is not performed frequently.	
Corrective action	Reduce the regeneration load. Choose the brake unit and brake resistor which have a larger capacity.	

\*1 This functions only when Pr:0 =\*1\*(BU mode (when a GRZG type brake resistor is connected)).

\*2 Resetting the brake unit initializes the internal thermal integrated data of the electronic thermal relay function.

Operation panel indication	FIN	Fin
Name	Fin overheat	
Description	If the heatsink overheats, the temperature sensor is actuated to stop the brake operation.	
Check point	1.Check for too high ambient temperature. 2.Check for heatsink clogging.	
Corrective action	1.Set the ambient temperature to within the specifications. 2.Clean the heatsink.	

Operation panel indication	BE	<b>BE</b>
Name	Brake transistor alarm detection	
Description	This function stops the inverter output if an alarm occurs in the brake circuit, e.g. damaged brake transistors.	
Check point	<ul style="list-style-type: none"> <li>• Reduce the load inertia.</li> <li>• Check that the frequency of using the brake is proper.</li> <li>• Check for mis-wiring with the resistor (brake in the cable).</li> </ul>	
Corrective action	<ul style="list-style-type: none"> <li>• Immediately turn off the inverter power and check the wiring.</li> <li>• Change the brake unit if wiring is correct.</li> </ul>	

Operation panel indication	OHT	<b>OHT</b>
Name	Resistor overheat alarm	
Description	When the external thermal relay provided for resistor overheat protection or the temperature relay, etc. switches on*, inputting the contacts in the brake unit stops brake operation.	
Check point	<ul style="list-style-type: none"> <li>• Check for resistor overheating.</li> </ul>	
Corrective action	<ul style="list-style-type: none"> <li>• Reduce the load and frequency of operation.</li> <li>• Even if the relay contacts are reset automatically, the brake will not restart unless it is reset.</li> </ul>	

Operation can be selected using *Pr.2 and Pr.3 (input terminal function selection)* . Set according to the resistor unit to be connected. (Refer to page 36)

Operation panel indication	PE	<b>PE</b>
Name	Parameter storage device alarm	
Description	Appears when an error occurred in the stored parameters. (EEPROM fault)	
Check point	Check for too many number of parameter write times.	
Corrective action	Please contact your sales representative.	

Operation panel indication	CPU	<b>CPU</b>
Name	CPU Fault	
Description	Appears during the built-in CPU and peripheral circuit errors occurred.	
Check point	Check for devices producing excess electrical noises around the brake unit.	
Corrective action	<ul style="list-style-type: none"> <li>• Take measures against noises if there are devices producing excess electrical noises around the brake unit.</li> <li>• Please contact your sales representative.</li> </ul>	

---



---

**CAUTION**

**If alarms other than the above appear, contact your sales representative.**

---



---



## 5.2 Correspondence Between Digital and Actual Characters

There are the following correspondences between the actual alphanumeric characters and the digital characters displayed on the operation panel:

Actual	Indication	Actual	Indication	Actual	Indication
0		A		M	
1		B		N	
2		C		O	
3		D		o	
4		E		P	
5		F		S	
6		G		T	
7		H		U	
8		I		V	
9		J		r	
		L		-	

## 6 SPECIFICATIONS

### 6.1 Brake Unit

Specifications	200V						400V					
	Type	FR-BU2-□	1.5K	3.7K	7.5K	15K	30K	55K	H7.5K	H15K	H30K	H55K
Applicable motor capacity	Capacity of the motor to be used with differs according to the braking torque and duty (%ED)											
Connected brake resistance	GRZG type, FR-BR type, MT-BR5 type											
Multiple (parallel) operation	10 units maximum (Note that torque generated is not more than the tolerable overcurrent amount of connected inverter)											
Cooling system	Natural cooling											
Protective structure	IP00											
Approximate mass(kg)	0.9	0.9	0.9	0.9	1.4	2.0	0.9	0.9	1.4	2.0	2.0	2.0

### 6.2 Brake Resistor/Resistor Unit

#### (1) FR-BR type

Resistor Unit Type		Brake Resistor Total Resistance Value	Continuous Permissible Power
200V	FR-BR-15K	8 Ω	990W
	FR-BR-30K	4 Ω	1990W
	FR-BR-55K	2 Ω	3910W
400V	FR-BR-H15K	32 Ω	990W
	FR-BR-H30K	16 Ω	1990W
	FR-BR-H55K	8 Ω	3910W

#### (2) GZG, GRZG type

Resistor Unit Type		Brake Resistor Total Resistance Value	Continuous Permissible Power
200V	GZG 300W-50 Ω (one)	50 Ω	100W
	GRZG 200-10 Ω (three in series)	30 Ω	300W
	GRZG 300-5 Ω (four in series)	20 Ω	600W
	GRZG 400-2 Ω (six in series)	12 Ω	1200W
400V	GRZG 200-10 Ω (six in series)	60 Ω	600W
	GRZG 300-5 Ω (eight in series)	40 Ω	1200W
	GRZG 400-2 Ω (twelve in series)	24 Ω	2400W

#### (3) MT-BR5 type

Resistor Unit Type		Brake Resistor Total Resistance Value	Continuous Permissible Power
200V	MT-BR5-55K	2 Ω	5500W
400V	MT-BR5-H75K	6.5 Ω	7500W

# 7 PRECAUTIONS FOR MAINTENANCE AND INSPECTION

---

The brake unit is a static unit mainly consisting of semiconductor devices. Daily inspection must be performed to prevent any fault from occurring due to the adverse effects of the operating environment, such as temperature, humidity, dust, dirt and vibration, changes in the parts with time, service life, and other factors.

## ***7.1 Precautions for Maintenance and Inspection***

For some short time after the power is switched off, a high voltage remains in the smoothing capacitor. When accessing the brake unit for inspection, wait for at least 10 minutes after the power supply has been switched off, and then make sure that the voltage across the main circuit terminals P-N of the brake unit is not more than 30VDC using a tester, etc.

## ***7.2 Inspection Item***

### (1) Daily inspection

- Basically, check for the following faults during operation.
  - 1) Improper installation environment
  - 2) Cooling system fault
  - 3) Unusual vibration and noise
  - 4) Unusual overheat and discoloration

### (2) Cleaning

Always run the brake unit in a clean status.

When cleaning the inverter, gently wipe dirty areas with a soft cloth immersed in neutral detergent or ethanol.

---

### **CAUTION**

---

**Do not use solvent, such as acetone, benzene, toluene and alcohol, as they will cause the inverter surface paint to peel off.**

---

### **7.3 Periodic Inspection**

Check the areas inaccessible during operation and requiring periodic inspection. Consult us for periodic inspection.

- 1) Cooling system fault ..... Clean the air filter, etc.
- 2) Tightening check and retightening..... The screws and bolts may become loose due to vibration, temperature changes, etc. Check and tighten them.  
Check and tighten them. Tighten them according to the specified tightening torque.
- 3) Check the conductors and insulating materials for corrosion and damage.
- 4) Measure insulation resistance.
- 5) Check and replace the cooling fan, smoothing capacitor and relay.



## 7.4 Daily and Periodic Inspection

Area of Inspection	Inspection Item	Description	Interval		Corrective Action at Alarm Occurrence	Customer's Check
			Daily	Periodic *1		
General	Surrounding environment	Check the ambient temperature, humidity, dirt, corrosive gas, oil mist, etc.	○		Improve environment.	
	Overall unit	Check for unusual vibration and noise.	○		Check alarm location and retighten.	
Main circuit	General	(1)Check with megger (across main circuit terminals and earth (ground) terminal). (2)Check for loose screws and bolts. (3)Check for overheat traces on the parts. (4)Check for stain.		○ ○ ○ ○	Contact the manufacturer. Retighten. Contact the manufacturer. Clean.	
	Conductors, cables	Check cable sheaths for breakage and deterioration (crack, discoloration, etc.).		○	Contact the manufacturer.	
	Terminal block	Check for damage.		○	Stop the device and contact the manufacturer.	
	Resistor	(1)Check for crack in resistor insulation. (2) Check for unusual odor.		○ ○	Contact the manufacturer. Contact the manufacturer.	
Control circuit/protective circuit	Operation check	Check that no fault is found in protective and display circuits in a sequence protective operation test.		○	Contact the manufacturer.	
	Parts check	Overall	(1)Check for unusual odor and discoloration. (2)Check for serious rust development .	○ ○	Stop the device and contact the manufacturer. Contact the manufacturer.	
		Aluminum electrolytic capacitor	Check for liquid leakage in a capacitor and deformation trace.		○	Contact the manufacturer.
Cooling system	Heatsink	(1)Check for clogging. (2)Check for stain.		○ ○	Clean. Clean.	
	Air filter, etc.	(1)Check for clogging. (2)Check for stain.		○ ○	Clean or replace. Clean or replace.	
Indication	Indication	(1)Check that display is normal. (2)Check for stain.	○	○	Contact the manufacturer. Clean.	

\*1 One to two years of periodic inspection cycle is recommended. However, it differs according to the installation environment. Consult us for periodic inspection.

## 7.5 Replacement of Parts

The brake unit consists of many electronic parts such as semiconductor devices. The following parts may deteriorate with age because of their structures or physical characteristics, leading to reduced performance or fault of the brake unit. For preventive maintenance, the parts must be replaced periodically.

Part Name	Standard Replacement Interval	Description
On-board smoothing capacitor	10 years*	Replace the board (as required)
Relays	—	as required

\* The design life of electrolytic capacitor is about ten years (36000h) if used for 10 hours a day and 365 days a year in the average yearly ambient temperature of 40 °C.

### CAUTION

**For parts replacement, consult the nearest Mitsubishi FA Center.**

#### (1) Smoothing capacitors

An aluminum electrolytic capacitor is used for stabilizing the control power in the control circuit. The characteristics is deteriorated by the adverse effects of ripple currents, etc. The replacement intervals greatly vary with the ambient temperature and operating conditions. When the inverter is operated in air-conditioned, normal environment conditions, replace the capacitors about every 10 years.

When a certain period of time has elapsed, the capacitors will deteriorate more rapidly. Check the capacitors at least every year (less than six months if the life will be expired soon).

The appearance criteria for inspection are as follows:

- 1) Case: Check the side and bottom faces for expansion.
- 2) Sealing plate: Check for remarkable warp and extreme crack.
- 3) Check for external crack, discoloration, liquid leakage, etc. Judge that the capacitor has reached its life when the measured capacitance of the capacitor reduced below 85% of the rating.

#### (2) Relays

To prevent a contact fault, etc., relays must be replaced according to the cumulative number of switching times (switching life).



# 8 SELECTION

## (1) Selection of Brake Unit

- 1) Select the brake unit according to the motor capacity.
- 2) To obtain the braking torque not less than 200%, use a larger inverter in capacity.

<GZG, GRZG type are connected>

Power supply Voltage	Motor (kW)	Braking Torque						
		0.4	0.75	1.5	2.2	3.7	5.5	7.5
200V class	50%30s	FR-BU2-1.5K			FR-BU2-3.7K		FR-BU2-7.5K	
	100%30s	FR-BU2-1.5K		FR-BU2-3.7K	FR-BU2-7.5K		FR-BU2-15K	
400V class	50%30s	—*2			FR-BU2-H7.5K			
	100%30s	—*2			FR-BU2-H7.5K		FR-BU2-H15K	

Power supply voltage	Motor (kW)	Braking Torque							
		11	15	18.5	22	30	37	45	55
200V class	50%30s	FR-BU2-15K	2×FR-BU2-15K*1			3×FR-BU2-15K*1		4×FR-BU2-15K*1	
	100%30s	2×FR-BU2-15K*1	3×FR-BU2-15K*1	4×FR-BU2-15K*1	5×FR-BU2-15K*1	6×FR-BU2-15K*1	7×FR-BU2-15K*1		
400V class	50%30s	FR-BU2-H15K	FR-BU2-H30K			2×FR-BU2-H30K*1			
	100%30s	FR-BU2-H30K	2×FR-BU2-H30K*1		3×FR-BU2-H30K*1		4×FR-BU2-H30K*1		

\*1 The number before the model name explains the number of connectable units in parallel. (Refer to page 19 )

\*2 The inverter of 1.5K or less can not be used in combination with a brake unit. To use in combination with a brake unit, use the inverter of 2.2K or more.

<When FR-BR is connected>

- %ED at short-time rating when braking torque is 100%

Motor Capacity		5.5 kW	7.5 kW	11 kW	15k W	18.5 kW	22 kW	30 kW	37 kW	45 kW	55 kW
200V	FR-BU2-15K	%ED	80	40	15	10	—	—	—	—	—
	FR-BU2-30K		—	—	65	30	25	15	10	—	—
	FR-BU2-55K		—	—	—	—	90	60	30	20	15
400V	FR-BU2-H15K	%ED	80	40	15	10	—	—	—	—	—
	FR-BU2-H30K		—	—	65	30	25	15	10	—	—
	FR-BU2-H55K		—	—	—	—	90	60	30	20	15

- Braking torque (%) at short-time rating of 15s

Motor Capacity		5.5 kW	7.5 kW	11 kW	15 kW	18.5 kW	22 kW	30 kW	37 kW	45 kW	55 kW
200V	FR-BU2-15K	Braking torque (%)	280	200	120	100	80	70	—	—	—
	FR-BU2-30K		—	—	260	180	160	130	100	80	70
	FR-BU2-55K		—	—	—	—	300	250	180	150	120
400V	FR-BU2-H15K	Braking torque (%)	280	200	120	100	80	70	—	—	—
	FR-BU2-H30K		—	—	260	180	160	130	100	80	70
	FR-BU2-H55K		—	—	—	—	300	250	180	150	120

$$\text{Regeneration duty factor (operation frequency)\%ED} = \frac{t_b}{t_c} \times 100 \quad t_b < 15\text{s (continuous operation time)}$$

Example 1 Travel operation

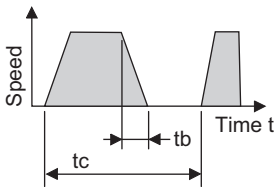

Example 2 Lift operation

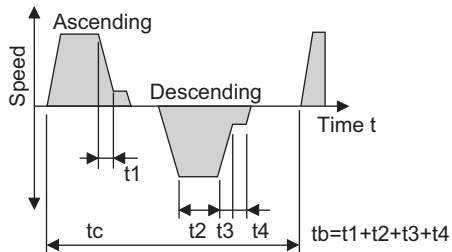

\* Do not use with a conventional BU type brake unit.



<MT-BR5 is connected>

- ED at short-time rating when braking torque is 100%

Motor Capacity		75 kW	90 kW	110 kW	132 kW	160 kW	185 kW	220 kW	280 kW	375 kW
200V	FR-BU2-55K	5	—	—	—	—	—	—	—	—
	2×FR-BU2-55K*1	20	15	10	—	—	—	—	—	—
400V	FR-BU2-H75K	10	5	—	—	—	—	—	—	—
	2×FR-BU2-H75K*1	40	25	20	10	5	5	—	—	—
	3×FR-BU2-H75K*1	80	60	40	25	15	10	10	5	—
	4×FR-BU2-H75K*1	—	80	65	40	30	20	15	10	5
	5×FR-BU2-H75K*1	—	—	—	80	50	40	20	15	10

- Braking torque (%) at short-time rating of 15s

Motor Capacity		75 kW	90 kW	110 kW	132 kW	160 kW	185 kW	220 kW	280 kW	375 kW
200V	FR-BU2-55K	70	60	50	—	—	—	—	—	—
	2×FR-BU2-55K*1	150	120	100	—	—	—	—	—	—
400V	FR-BU2-H75K	100	80	70	55	45	40	35	25	20
	2×FR-BU2-H75K*1	150	150	135	110	90	80	70	50	40
	3×FR-BU2-H75K*1	150	150	150	150	135	115	100	80	55
	4×FR-BU2-H75K*1	150	150	150	150	150	150	125	100	70
	5×FR-BU2-H75K*1	150	150	150	150	150	150	150	130	100

- \*1 The number before the model name explains the number of connectable units in parallel.  
(Refer to page 26 )
- \*2 To obtain a large braking torque, the motor has to have a torque characteristic that meets the braking torque.  
Check the torque characteristic of the motor.

# 9 OUTLINE DIMENSION DRAWINGS

## (1) Brake Unit

- FR-BU2-1.5K to 15K  
FR-BU2-H7.5K, H15K

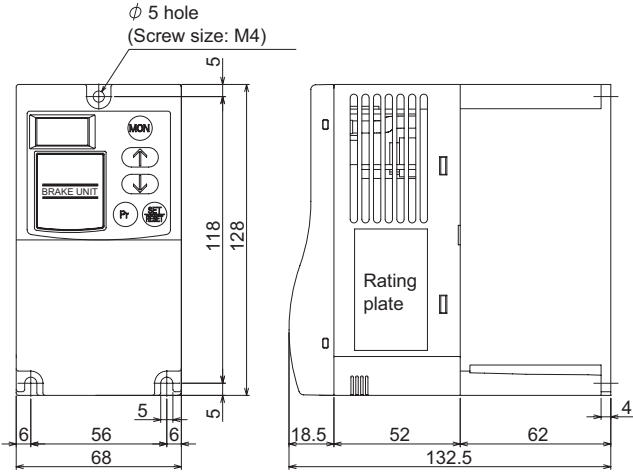

(Unit: mm)

- FR-BU2-30K  
FR-BU2-H30K

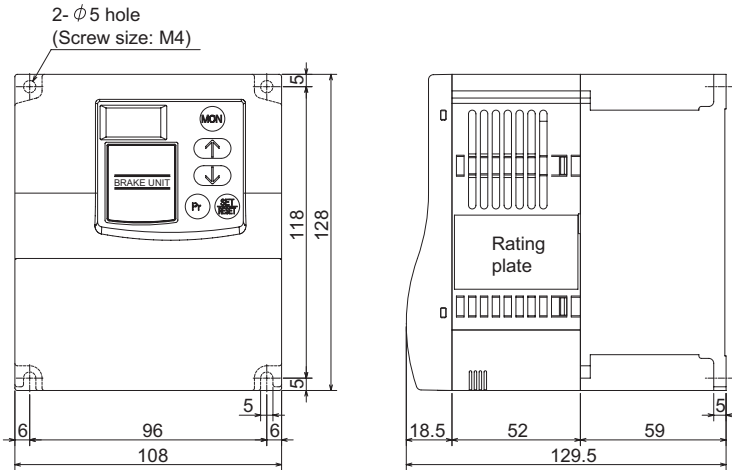

(Unit: mm)



- FR-BU2-55K  
FR-BU2-H55K, H75K

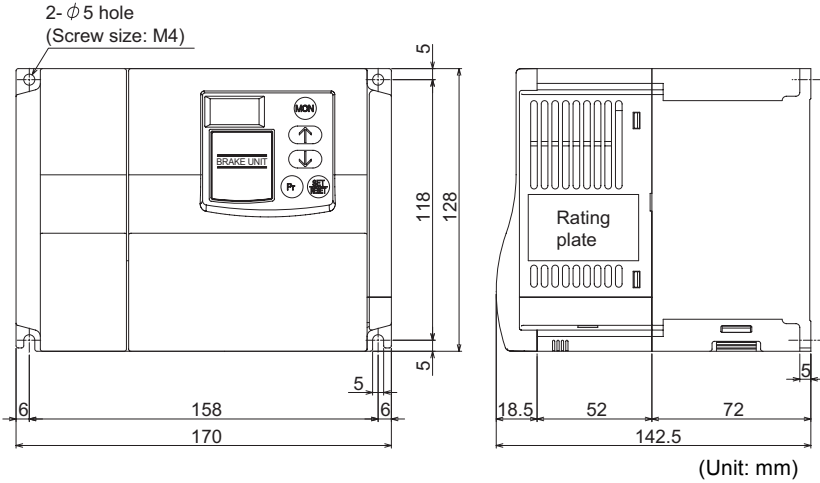

(2) Resistor unit

<GRZG type>

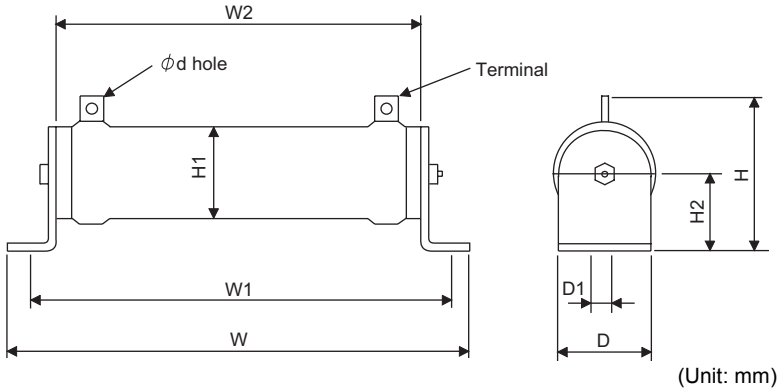

Model	W	W1	W2	H	H1	H2	D	D1	d
GZG300W	335	309	274	78	42	40	40	9.5	5.5
GRZG200	306	287	266	53	33	22	26	6	5.5
GRZG300	334	309	274	79	47	40	40	9.5	5.5
GRZG400	411	385	350	79	47	40	40	9.5	5.5

- The maximum temperature rise of the brake resistors is approximately 200deg or more. For wiring, therefore, use heat-resistant wires (such as fiber-glass braided wires) or cover the wires with silicone tube. Also perform wiring so that the wires do not make contact with the resistors. Also, separate a component, which is low in heat-resistant property, at least 15 to 20cm from the resistors.

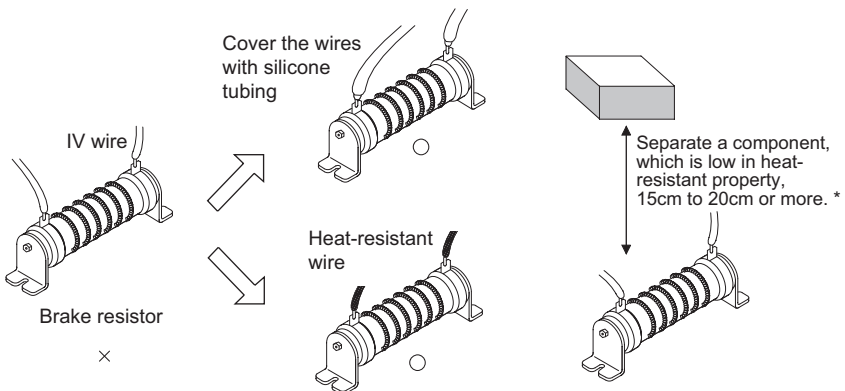

\* When it is inevitable to place a component, which is low in the heat-resisting property, in the vicinity of the resistors, mount a temperature sensor to the component with low heat-resisting property and make up a sequence which shuts off power of the inverter input side by the temperature sensor signal. For the temperature sensor, contact the manufacturer.



<FR-BR type>

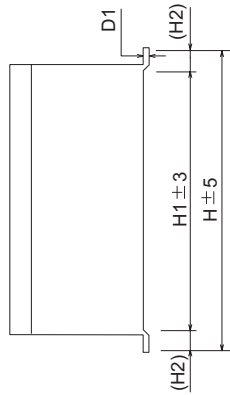
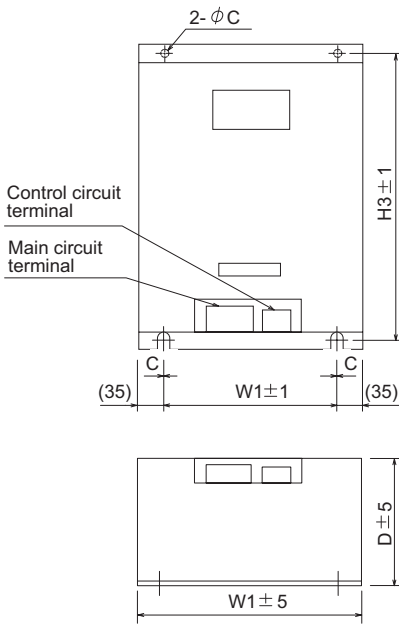

The FR-BR-55K and H55K are provided with two eyebolts. (see below)

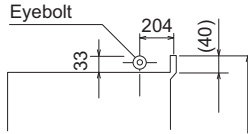

(Unit: mm)

Resistor Unit Type		W	W1	H	H1	H2	H3	D	D1	C	Approximate Mass (kg)
200V	FR-BR-15K	170	100	450	410	20	432	220	3.2	6	15
	FR-BR-30K	340	270	600	560	20	582	220	4	10	30
	FR-BR-55K	480	410	700	620	40	670	450	3.2	12	70
400V	FR-BR-H15K	170	100	450	410	20	432	220	3.2	1.6	15
	FR-BR-H30K	340	270	600	560	20	582	220	4	10	30
	FR-BR-H55K	480	410	700	620	40	670	450	3.2	12	70

\*1 Ventilating openings are provided on both left and right side surfaces and on the top surface. The bottom side is open.

\*2 The temperature rise of the resistor unit is about a maximum of 100 deg. Therefore, use heat-resistant wires (such as glass wires) or cover the wires with silicone tubing.

<MT-BR5 type>

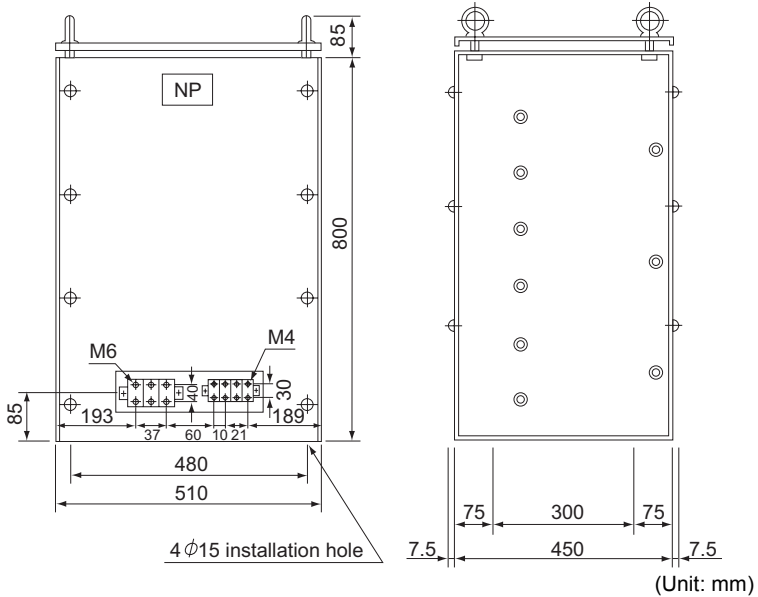

- \*1 Be sure to select the well-ventilated place for installation of the resistor unit. Ventilation is necessary when installing the resistor in a place, e.g. enclosure, where heat is not well diffused.
- \*2 The temperature rise of the resistor unit is 300deg. Therefore, wire the cable so as not to touch the resistor. Also, separate a component, which is low in heat-resistant property, at least 40 to 50cm from the resistors.
- \*3 The temperature of the resistor unit abnormally increases if the brake unit is operated exceeding the specified duty. Since the resistor unit may result in overheat if the temperature of the brake unit is left unchanged, switch off the inverter.
- \*4 The resistor unit is provided with a thermostat (a contact) as overheat protection. If this protective device is activated under normal operation, it is assumed that the deceleration time is too short. In such a case, increase the deceleration time setting of the inverter.

Resistor Unit Type		Resistance Value	Approximate Mass (kg)
200V class	MT-BR5-55K	2.0Ω	50
400V class	MT-BR5-H75K	6.5Ω	70



# 10 INSTRUCTIONS FOR UL, CSA STANDARD COMPLIANCE

---

## **Instructions for UL, CSA standard compliance (UL mark is printed on UL qualified products)**

### **1. UL standard**

UL standard is the general standard of motor control devices in the United States. Safety standard for devices, equipments, materials are established to protect human life and property from fire, electric shock, and other accidents. The FR-BU2 is considered as part of power converter and subject to UL508C(Power Conversion Equipment) .

### **2. Necessity of UL qualification**

Laws in the U.S.A are divided into federal laws and municipal laws of states and cities. The federal government stipulates minimum regulations only and local governments set specific rules. UL standard is not therefore enforced by a federal law. However, some local governments specify the necessity of product safety certification by the UL or other testing agency and even some local governments without regulations require that products should satisfy minimum standard which meets "safety products" set by a federal law.

### **3. Instructions**

Refer to below to use the FR-BU2(H) series as a UL qualified product.

(1) Wiring the brake unit with the inverter and resistor unit

For wiring terminals (N/-, P/+, PR) of the inverter, brake unit, and resistor unit, *refer to page 6* and choose UL-listed round crimping terminals. Crimp the crimping terminals with the crimping tool recommended by the terminal maker.

(2) Brake duty

Brake duty is 10%ED maximum.

MEMO

## REVISIONS

\*The manual number is given on the bottom left of the back cover.

Print Date	*Manual Number	Revision
Sep., 2006	IB(NA)-0600292ENG-A	First edition