



# YK610XE-10

Standard type: Medium type

● LOW COST HIGH PERFORMANCE MODEL



- Arm length 610mm
- Maximum payload 10kg

## Ordering method

**YK610XE-10-200**

|              |                        |                      |                                       |  |   |                                |   |                        |                                  |                         |
|--------------|------------------------|----------------------|---------------------------------------|--|---|--------------------------------|---|------------------------|----------------------------------|-------------------------|
| <b>Model</b> | <b>Maximum payload</b> | <b>Z axis stroke</b> | <b>Tool flange</b>                    | <b>Hollow shaft/cap</b> <small>Note</small>                  | <b>Brake release switch</b>                     | <b>Cable</b>                   | <b>Controller / Number of controllable axes</b> | <b>Safety standard</b> | <b>Option A to E (OP.A to E)</b> | <b>Absolute battery</b> |
|              |                        |                      | No entry: None<br>F: With tool flange | No entry: None<br>S: With hollow shaft<br>C: With hollow cap | No entry: None<br>BS: With brake release switch | 3L: 3.5m<br>5L: 5m<br>10L: 10m | <b>RCX340-4</b>                                 |                        |                                  |                         |

Specify various controller setting items.  
RCX340 ▶ **P.678**

Note. The return-to-origin method is provided only in the sensor specifications, but not in the stroke end specifications.

## Specifications

|  |                               | X-axis   | Y-axis     | Z-axis      | R-axis     |
|--|-------------------------------|--|------------|-------------|------------|
| <b>Axis specifications</b>   | <b>Arm length</b>             | 335 mm   | 275 mm     | 200 mm      | -          |
|  | <b>Rotation angle</b>         | +/-134 °   | +/-152 °   | -           | +/-360 °   |
| <b>AC servo motor output</b>                                       |                               | 400 W  | 200 W      | 200 W       | 200 W      |
| <b>Deceleration mechanism</b>                                      | <b>Transmission method</b>    | Direct-coupled   |            | Timing belt |            |
|  | <b>Motor to speed reducer</b> | Direct-coupled   |            | Timing belt |            |
| <b>Speed reducer to output</b>                                     |                               | Direct-coupled   |            | Timing belt |            |
|  |                               | Direct-coupled   |            | Timing belt |            |
| <b>Repeatability</b> <small>Note 1</small>                         |                               | +/-0.01 mm   | +/-0.01 mm | +/-0.01 °   |            |
| <b>Maximum speed</b>   |                               | 8.6 m/sec  |            | 2 m/sec     | 2600 °/sec |
| <b>Maximum payload</b>   |                               | 10 kg (Standard specification, Option specifications <small>Note 4</small> ),<br>9 kg (Option specifications <small>Note 5</small> ) |            |             |            |
| <b>Standard cycle time: with 2kg payload</b> <small>Note 2</small> |                               | 0.39 sec   |            |             |            |
| <b>R-axis tolerable moment of inertia</b> <small>Note 3</small>    |                               | 0.3 kgm <sup>2</sup>   |            |             |            |
| <b>User wiring</b>   |                               | 0.2 sq × 20 wires  |            |             |            |
| <b>User tubing (Outer diameter)</b>                                |                               | φ 6 × 3  |            |             |            |
| <b>Travel limit</b>  |                               | 1.Soft limit 2.Mechanical stopper (X,Y,Z axis)   |            |             |            |
| <b>Robot cable length</b>  |                               | Standard: 3.5 m Option: 5 m, 10 m  |            |             |            |
| <b>Weight</b>  |                               | 25 kg  |            |             |            |

Note 1. This is the value at a constant ambient temperature. (X,Y axes)  
 Note 2. When reciprocating 300mm in horizontal and 25mm in vertical directions and performing the coarse positioning arch operation.  
 Note 3. The acceleration coefficient is set automatically in accordance with the tip weight and offset amount for R-axis moment of inertia settings.  
 Note 4. Maximum payload of the standard or option specifications (brake release switch type, user wiring/tubing through cap type) is 10 kg.  
 Note 5. Maximum payload of the option specifications (tool flange mount type, user wiring/tubing through shaft type) is 9 kg.

## Controller

| Controller | Power capacity (VA) | Operation method   |
|------------|---------------------|--|
| RCX340     | 1700                | Programming / I/O point trace / Remote command / Operation using RS-232C communication |

Note. The movement range can be restricted by adding the X- and Y-axis mechanical stoppers. (The maximum movement range was set at shipment.)  
 See our robot manuals (installation manuals) for detailed information.

Note. To set the standard coordinates with high accuracy, use a standard coordinate setting jig (option). Refer to the user's manual (installation manual) for more details.

Our robot manuals (installation manuals) can be downloaded from our website at the address below:  
<https://global.yamaha-motor.com/business/robot/>

## YK610XE-10

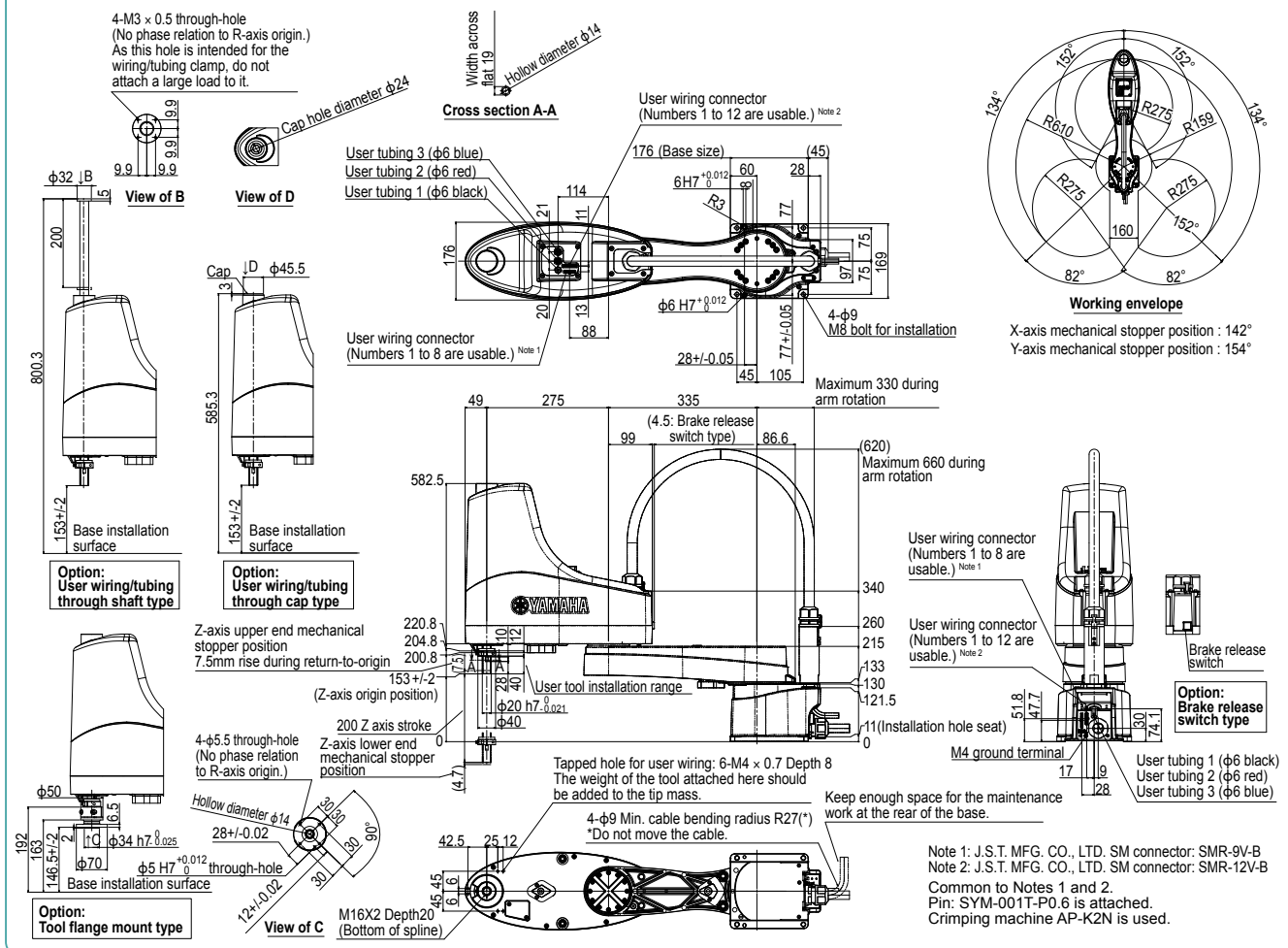

Note 1: J.S.T. MFG. CO., LTD. SM connector: SMR-9V-B  
 Note 2: J.S.T. MFG. CO., LTD. SM connector: SMR-12V-B  
 Common to Notes 1 and 2.  
 Pin: SYM-001T-P0.6 is attached.  
 Crimping machine AP-K2N is used.

# YK710XE-10

Standard type: Large type

● LOW COST HIGH PERFORMANCE MODEL



● Arm length 710mm ● Maximum payload 10kg

## Ordering method

**YK710XE-10-200**

| Model | Maximum payload | Z axis stroke | Tool flange                           | Hollow shaft/cap <sup>Note</sup>                             | Brake release switch                            | Cable                          |
|-------|-----------------|---------------|---------------------------------------|--|---|--------------------------------|
|       |                 |               | No entry: None<br>F: With tool flange | No entry: None<br>S: With hollow shaft<br>C: With hollow cap | No entry: None<br>BS: With brake release switch | 3L: 3.5m<br>5L: 5m<br>10L: 10m |

**RCX340-4**

| Controller / Number of controllable axes | Safety standard | Option A to E (OP.A to E) | Absolute battery |
|--|-----------------|---------------------------|------------------|
|  |                 |                           |                  |

Specify various controller setting items.  
RCX340 ▶ **P.678**

Note. The return-to-origin method is provided only in the sensor specifications, but not in the stroke end specifications.

## Specifications

|   |                         | X-axis   | Y-axis   | Z-axis      | R-axis     |
|---|-------------------------|--|----------|-------------|------------|
| Axis specifications                                     | Arm length              | 435 mm   | 275 mm   | 200 mm      | -          |
|   | Rotation angle          | +/-134 °   | +/-152 ° | -           | +/-360 °   |
| AC servo motor output                                   |                         | 400 W  | 200 W    | 200 W       | 200 W      |
| Deceleration mechanism                                  | Transmission method     | Direct-coupled   |          | Timing belt |            |
|   | Motor to speed reducer  | Direct-coupled   |          | Timing belt |            |
|   | Speed reducer to output | Direct-coupled   |          | Timing belt |            |
| Repeatability <sup>Note 1</sup>                         |                         | +/-0.02 mm   |          | +/-0.01 mm  | +/-0.01 °  |
| Maximum speed   |                         | 9.5 m/sec  |          | 2 m/sec     | 2600 °/sec |
| Maximum payload   |                         | 10 kg (Standard specification, Option specifications <sup>Note 4</sup> ),<br>9 kg (Option specifications <sup>Note 5</sup> ) |          |             |            |
| Standard cycle time: with 2kg payload <sup>Note 2</sup> |                         | 0.42 sec   |          |             |            |
| R-axis tolerable moment of inertia <sup>Note 3</sup>    |                         | 0.3 kgm <sup>2</sup>   |          |             |            |
| User wiring   |                         | 0.2 sq × 20 wires  |          |             |            |
| User tubing (Outer diameter)                            |                         | φ 6 × 3  |          |             |            |
| Travel limit  |                         | 1.Soft limit 2.Mechanical stopper (X,Y,Z axis)   |          |             |            |
| Robot cable length                                      |                         | Standard: 3.5 m Option: 5 m, 10 m  |          |             |            |
| Weight  |                         | 26 kg  |          |             |            |

Note 1. This is the value at a constant ambient temperature. (X,Y axes)  
 Note 2. When reciprocating 300mm in horizontal and 25mm in vertical directions and performing the coarse positioning arch operation.  
 Note 3. The acceleration coefficient is set automatically in accordance with the tip weight and offset amount for R-axis moment of inertia settings.  
 Note 4. Maximum payload of the standard or option specifications (brake release switch type, user wiring/tubing through cap type) is 10 kg.  
 Note 5. Maximum payload of the option specifications (tool flange mount type, user wiring/tubing through shaft type) is 9 kg.

## Controller

| Controller | Power capacity (VA) | Operation method   |
|------------|---------------------|--|
| RCX340     | 1700                | Programming / I/O point trace / Remote command / Operation using RS-232C communication |

Note. The movement range can be limited by changing the positions of X and Y axis mechanical stoppers. (The movement range is set to the maximum at the time of shipment.)  
 See our robot manuals (installation manuals) for detailed information.

Note. To set the standard coordinates with high accuracy, use a standard coordinate setting jig (option). Refer to the user's manual (installation manual) for more details.

Our robot manuals (installation manuals) can be downloaded from our website at the address below:  
<https://global.yamaha-motor.com/business/robot/>

## YK710XE-10

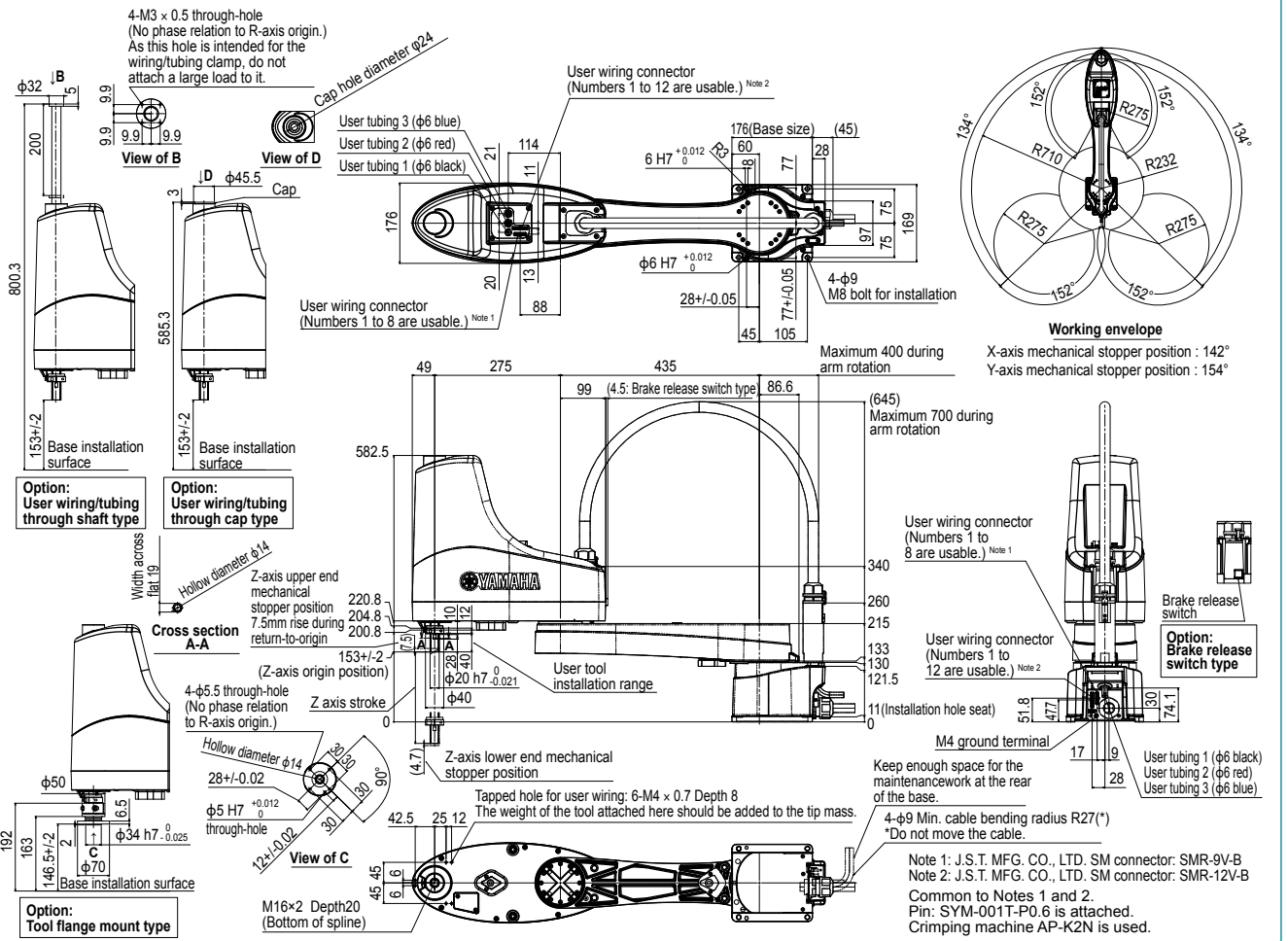

# YK400XE-4

Standard type: Small type

LOW COST HIGH PERFORMANCE MODEL



- Arm length 400mm
- Maximum payload 4kg

## Ordering method

|                  |                        |  |                      |   |  |  |   |                        |                                  |                         |  |  |  |  |  |
|------------------|------------------------|--|----------------------|---|--|--|---|------------------------|----------------------------------|-------------------------|--|--|--|--|--|
| <b>YK400XE-4</b> | <b>150</b>             |  |                      |   |  |  |   |                        |                                  | <b>RCX340-4</b>         |  |  |  |  |  |
| <b>Model</b>     | <b>Maximum payload</b> | <b>Return-to-origin method</b><br>S: Sensor<br>T: Stroke end | <b>Z axis stroke</b> | <b>Hollow shaft</b><br>No entry: None<br>S: With hollow shaft | <b>Brake release switch</b><br>No entry: None<br>BS: With brake release switch | <b>Cable</b><br>3L: 3.5m<br>5L: 5m<br>10L: 10m | <b>Controller / Number of controllable axes</b> | <b>Safety standard</b> | <b>Option A to E (OP.A to E)</b> | <b>Absolute battery</b> | <b>Specify various controller setting items.</b> |  |  |  |  |
|                  |                        |  |                      |   |  |  |   |                        |                                  |                         | <b>RCX340 ▶ P.678</b>                            |  |  |  |  |

## Specifications

|  |   | X-axis  | Y-axis     | Z-axis      | R-axis  |
|--|---|---|------------|-------------|---------|
| <b>Axis specifications</b>                                     | <b>Arm length</b>   | 225 mm  | 175 mm     | 150 mm      | -       |
|  | <b>Rotation angle</b>   | +/-132°   | +/-150°    | -           | +/-360° |
| <b>AC servo motor output</b>                                   |   | 200 W   | 100 W      | 100 W       | 100 W   |
| <b>Deceleration mechanism</b>                                  | <b>Transmission method</b>                                      | Direct-coupled  |            | Timing belt |         |
|  | <b>Motor to speed reducer</b><br><b>Speed reducer to output</b> | Direct-coupled  |            | Timing belt |         |
| <b>Repeatability</b> <sup>Note 1</sup>                         |   | +/-0.01 mm  | +/-0.01 mm | +/-0.01°    |         |
| <b>Maximum speed</b>   |   | 6 m/sec   | 1.1 m/sec  | 2600 °/sec  |         |
| <b>Maximum payload</b>   |   | 4 kg (Standard specification, Option specifications <sup>Note 4</sup> ),<br>3 kg (Option specifications <sup>Note 5</sup> ) |            |             |         |
| <b>Standard cycle time: with 2kg payload</b> <sup>Note 2</sup> |   | 0.41 sec  |            |             |         |
| <b>R-axis tolerable moment of inertia</b> <sup>Note 3</sup>    |   | 0.05 kgm <sup>2</sup>   |            |             |         |
| <b>User wiring</b>   |   | 0.2 sq × 10 wires   |            |             |         |
| <b>User tubing (Outer diameter)</b>                            |   | φ 4 × 3   |            |             |         |
| <b>Travel limit</b>  |   | 1.Soft limit 2.Mechanical stopper (X,Y,Z axis)  |            |             |         |
| <b>Robot cable length</b>                                      |   | Standard: 3.5 m Option: 5 m, 10 m   |            |             |         |
| <b>Weight</b>  |   | 17 kg   |            |             |         |

Note 1. This is the value at a constant ambient temperature. (X,Y axes)  
 Note 2. When reciprocating 300mm in horizontal and 25mm in vertical directions and performing the coarse positioning arch operation.  
 Note 3. The acceleration coefficient is set automatically in accordance with the tip weight and offset amount for R-axis moment of inertia settings.  
 Note 4. Maximum payload of the standard or option specifications (brake release switch type) is 4 kg.  
 Note 5. Maximum payload of the option specifications (user wiring/tubing through shaft type) is 3 kg.

## Controller

| Controller | Power capacity (VA) | Operation method   |
|------------|---------------------|--|
| RCX340     | 1000                | Programming / I/O point trace / Remote command / Operation using RS-232C communication |

Note. The movement range can be restricted by adding the X- and Y-axis mechanical stoppers. (The maximum movement range was set at shipment.)  
 See our robot manuals (installation manuals) for detailed information.

Note. To set the standard coordinates with high accuracy, use a standard coordinate setting jig (option). Refer to the user's manual (installation manual) for more details.

Our robot manuals (installation manuals) can be downloaded from our website at the address below:  
<https://global.yamaha-motor.com/business/robot/>

## YK400XE-4

4-M3 × 0.5 through-hole  
 (No phase relation to R-axis origin.)  
 As this hole is intended for the wiring/tubing clamp, do not attach a large load to it.

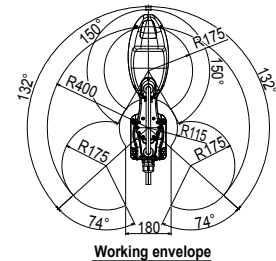
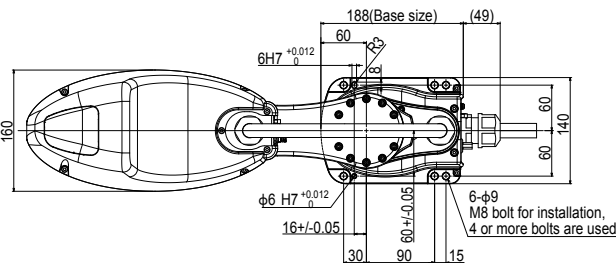
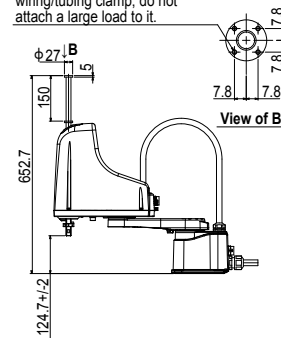

### Option User wiring/tubing through shaft type

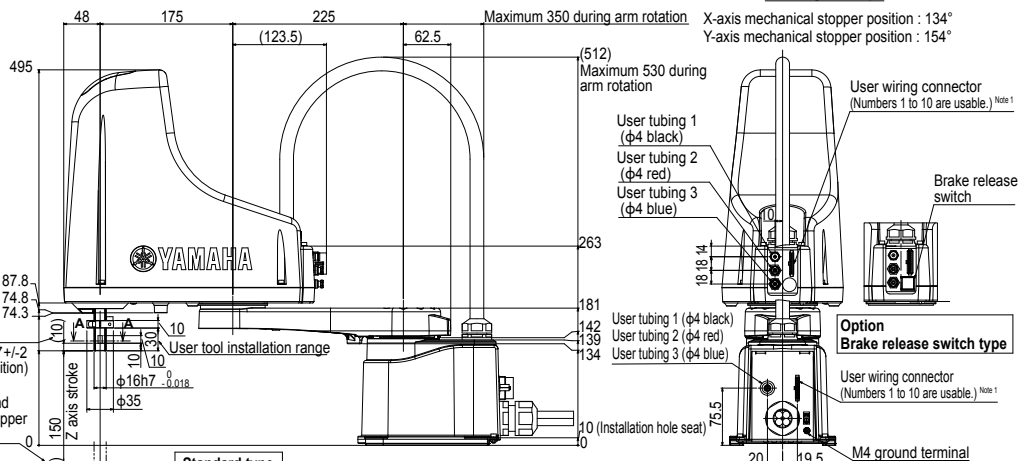
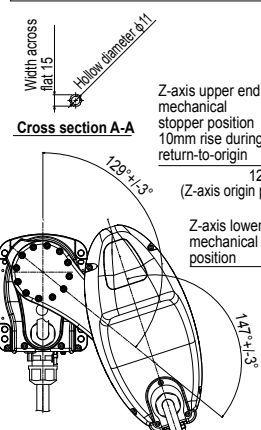

### Standard type

Tapped hole for user wiring: 6-M4 × 0.7 Depth 8  
 The weight of the tool attached here should be added to the tip mass.

Keep enough space for the maintenance work at the rear of the base.

4-φ9 Min. cable bending radius R27(\*)  
 \*Do not move the cable.

### XY-axis origin position (Stroke end specification)

When performing return-to-origin, move the X-axis and Y-axis counterclockwise and clockwise, respectively in advance from the position shown above.

Note 1: J.S.T. Mfg. Co., Ltd.  
 SM connector: SMR-11V-B  
 Pin: SYM-001T-P0.6 is attached.  
 Use AP-K2N for the crimping machine.