

Mitsubishi MAM series

Alarm Modems

Instruction Manual

Draft

MAM-GM6, GM20, GM24
MAM-AM6, AM20, AM24

About this Manual

The texts, illustrations, diagrams and examples in this manual are only intended as aids to help explain the functioning, operation, use and programming of the Mitsubishi Alarm Modems.

If you have any questions regarding the installation and operation of the software described in this manual, please do not hesitate to contact your sales office or one of your Mitsubishi distribution partners.

You can also obtain information and answers to frequently asked questions from our Mitsubishi website under www.mitsubishi-automation.com.

MITSUBISHI ELECTRIC reserves the right to change the specifications of its products and/or the contents of this manual at any time and without prior notice.

© 10/2005

Instruction Manual
Alarm Modems AM and GM series
Art-No.: 165590

Version			Changes / Additions / Corrections
A	09/2005	pdp-ck	First Edition



Security Advice

Intended Target Audience

This manual is aimed exclusively at suitably qualified electrical engineering specialists that are familiar with the safety standards required for electrical engineering and automation. The engineering, installation, commissioning, maintenance and testing of devices must only be carried out by qualified electrical technicians. Unless otherwise stated in this manual or other manuals, any intervention in the hardware and software of products must only be carried out by specialists.

Proper use

Mitsubishi Alarm Modems are only designed for use in the application fields described in this manual. Ensure that all the specifications stated in this manual are observed. Unqualified interventions in the hardware or software, and failure to observe the warnings stated in this manual or on the product may lead to serious injury or material damage. No liability is accepted in such cases and any warranty claims become invalid.

Safety instructions

The safety and accident prevention regulations specified for the application concerned must be observed during the engineering, installation, maintenance and testing of devices.

This manual contains special instructions that are important for the safe and proper handling of the device. The warning symbols of the individual instructions have the following meaning:



DANGER:

Means that there is a danger to the life and health of the user if the relevant safety measures are not taken.



ATTENTION:

Is a warning of possible damage to the device, software or other material damage if the relevant safety measures are not taken.

Contents

1	Mitsubishi Alarm Modems at a Glance	
1.1	State-Of-The-Art Communication	1-1
1.2	Easy To Retrofit	1-1
2	Function overview	
2.1	Integrated PLC protocols	2-1
2.2	Alarming with acknowledgment	2-1
2.3	Remote switching via SMS and Express-E-Mail	2-1
2.4	Teleservice via PC	2-2
2.5	Pump alarm application example	2-2
2.6	Model And Equipment Versions	2-2
3	Installation and Mounting	
3.1	Overview of the Connectors	3-1
3.1.1	Alarm Modem GSM	3-1
3.1.2	Alarm Modem 56k	3-2
3.2	Meaning of the LEDs	3-3
3.3	Mounting	3-4
3.4	Connecting the GSM antenna (only GM series)	3-5
3.5	Inserting the SIM card (only GM series)	3-6
3.6	Connection To The Telephone Network (only AM series)	3-7
3.6.1	Testing The Telephone Connection	3-7
3.6.2	The CLIP Feature	3-7
3.6.3	Telephone Exchange System	3-7
4	Interfaces	
4.1	COM1 – RS232 (Jack)	4-1
4.2	COM2 – RS232 (Plug)	4-1
4.3	Mitsubishi Alpha XL and Mitsubishi FX at RS232	4-2
4.3.1	Alpha XL	4-2
4.3.2	Mitsubishi FX1S, FX1N, FX2N, and FX2NC	4-2
4.4	RS485 / RS422	4-2

4.5	Mitsubishi FX at RS485/422	4-5
5 Power supply		
6 Operation		
7 Configuration and projects		
7.1	Initial configuration	7-1
7.2	Loading projects in the MAM	7-1
7.3	Loading projects remotely on the MAM	7-1
7.4	Operating the GSM Modem	7-1
7.4.1	PIN entry with MX-MAE software	7-1
7.4.2	PIN OK, network available, MAM logged in	7-1
7.4.3	PIN OK, no network, MAM not logged in	7-2
7.4.4	PIN incorrect, MAM not logged in	7-2
7.4.5	SIM card disabled, entry of the SUPER PIN	7-2
7.4.6	SIM Card Service Center	7-2
7.4.7	Caution in border regions: Logging in abroad	7-2
7.5	Operating modes: Modem Mode and TiXML Mode	7-3
7.5.1	Alarm Editor MX-MAE activates the correct mode	7-3
7.5.2	Using MAM without MX-MAE	7-3
7.5.3	TiXML Mode	7-3
7.5.4	Modem Mode (also AT mode)	7-3
7.5.5	Activating/deactivating Modem Mode	7-4
7.5.6	Sending commands to the MAM	7-4
8 Software		
8.1	MX Mitsubishi Alarm Editor MX-MAE	8-1
8.2	Secure Login: Access Protection	8-1
8.3	Remote Access	8-2
9 Communication with a PLC		
9.1	PLC driver in the Mitsubishi Alarm Modem	9-1
10 Appendix		
10.1	Technical data of the MAM series	10-1
10.2	LEDs, Reset, Update, Error Diagnostics	10-4
10.2.1	LEDs on restart	10-4
10.2.2	LEDs in the event of faults (only GM series)	10-4
10.2.3	Factory Reset	10-4

1 Mitsubishi Alarm Modems at a Glance

Mitsubishi Alarm Modems are new automatic modems with a large data memory, several functions and integrated Internet technology. They are designed as intelligent communication computers with a 32-bit power CPU and a 2 MB non-volatile Flash memory. This can now be expanded by up to 64 MB, thus providing enough space for your data requirements now and in the future.

Mitsubishi Alarm Modems are fully automatic and can

- send alarm and status messages via SMS or Express E-Mail,
- receive switch commands via SMS or Express E-Mail and forward them to a PLC,
- send the data of a connected PLC/system,
- transfer data between PLCs

What's more:

- You can use them as "normal" modems for the remote access of PLCs or systems, and the programming software of the PLC can generally be used for this.

1.1 State-Of-The-Art Communication

The Mitsubishi Alarm Modem can communicate directly with the Mitsubishi PLCs using the relevant PLC protocol. Modbus RTU and Modbus ASCII are also supported. User-friendly XML-based software programs enable the required functions to be configured easily. The over twenty year history of modems being controlled by primitive AT commands can now be forgotten at last.

The wide range of functions available on the Mitsubishi Alarm Modems provide solutions for a number of applications such as the monitoring of temperature, pressures, levels, or the activation of motors, fans, pumps slide valves and flaps.

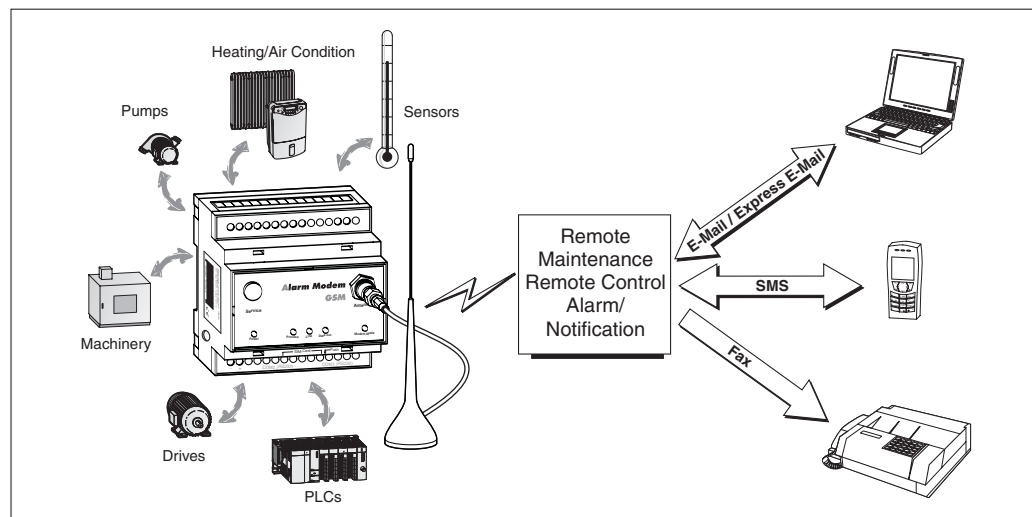

Fig.1-1 Communicating possibilities with the Mitsubishi Alarm Modem

1.2 Easy To Retrofit

Mitsubishi Alarm Modems can be integrated in existing systems with a minimum of effort. The communication protocols of commonly used PLCs are already implemented and so modifications to the PLC program are normally not required.

2 Function overview

2.1 Integrated PLC protocols

Mitsubishi Alarm Modems can communicate directly with the PLCs of leading manufacturers using the relevant PLC protocol, and access PLC variables, markers and ports via the PLC programming interface. This can be achieved without having to adapt the PLC program or load a special function block for communication.

These protocols are supported:

- Mitsubishi Alpha XL
- Mitsubishi MELSEC FX1S/FX1N and FX2N/FX2NC
- Mitsubishi System Q (in preparation)

2.2 Alarming with acknowledgment

Mitsubishi Alarm Modems are fully automatic and can send status and fault messages to any recipient via SMS, fax, e-mail or Express E-Mail. Messages can be triggered by PLC variables.



Address book:	The SMS, fax and e-mail addresses (max. 100) are managed in an address book.
Messages:	The message texts (max. 100) can contain up to 100 actual values from the PLC and can be of any required length when used with faxes and e-mails.
Alarms:	Up to 100 alarms and actions such as switching commands can be defined.
Alarm cascade and acknowledgments:	Any number of freely definable alarm levels can be set up if message acknowledgment is required. If a message is not acknowledged within a specified time, one or several recipients can be notified. This can be cascaded as required.

2.3 Remote switching via SMS and Express-E-Mail

A short command via SMS or Express E-Mail can switch the optional outputs of the Mitsubishi Alarm Modem and those of a connected PLC. PLC variables can also be set in this way.



The execution of the command can also be acknowledged. 100 SMS switch commands with up to 10 parameters each can be defined as required. PLC variables can be queried simply and quickly by SMS command without the need for a PC.

2.4 Teleservice via PC

A Mitsubishi Alarm Modem can be used to handle the remote maintenance of several controllers via a telephone line. This is usually possible with the programming software in use. The variables and I/O ports of the PLC can also be read or written remotely online with the Mitsubishi Alarm Editor (MX-AME). The entire configuration of the Mitsubishi Alarm Modem can be carried out by remote dial-in and the logged data can be read "manually".



Secure Login

Optimum security is ensured since unauthorized dial-in attempts are prevented by means of a login procedure with user name and password. All dial-in and dial-in attempts are recorded.

2.5 Pump alarm application example

The following example shows how you can use the wide range of functions of the Mitsubishi Alarm Modem to handle complex tasks automatically:

Pump alarm:

- ① Send an e-mail, a fax and an SMS to three different destinations if input X0 on the PLC closes.
- ② Wait ten minutes for a confirmation via SMS.
Service technicians can query status values by SMS (or dial-in and PC).
- ③ Wait for a switch command for reserve pump 2.
- ④ If the SMS confirmation does not come within 10 minutes, start a new alarm message cascade to other recipients.
- ⑤ If the switch command for switching on the reserve pump has been received, switch on the PLC output Y10 (or a relay).

2.6 Model And Equipment Versions

The Mitsubishi Alarm Modems were offered in two equipment versions: GM series (Alarm Modem GSM) and AM series (Alarm Modem 56k). The basic functions within these series are identical.

Mitsubishi Alarm Modems for GSM (GM)

Interfaces	MAM-GM6	MAM-GM20	MAM-GM24
COM1	RS232	RS232	RS232
COM2	—	RS232	RS485/422

Tab. 2-1 Interfaces of the GM series

Mitsubishi Alarm Modems 56k for the analog telephone line (AM)

Interfaces	MAM-AM6	MAM-AM20	MAM-AM24
COM1	RS232	RS232	RS232
COM2	—	RS232	RS485/422

Tab. 2-2 Interfaces of the AM series

3 Installation and Mounting

3.1 Overview of the Connectors

3.1.1 Alarm Modem GSM

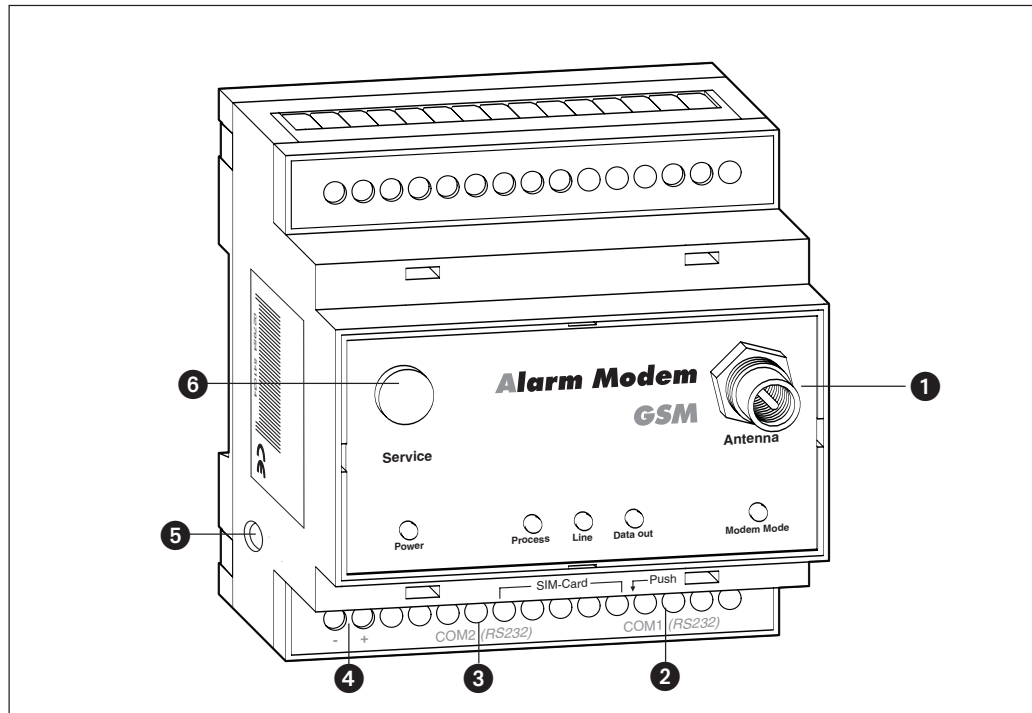

Fig. 3-1: Overview of all connectors of the Alarm Modem GSM

No.	Marking	Meaning
①	Antenna	Plug (FME) for Antenna cable (impedance: 50 Ω)
②	COM1 (RS232)	9pin D-Sub jack
③	COM2 (RS232)	9pin D-Sub plug (only MAM-GM20)
④	10...30 V DC	Power supply (2 screw terminals)
⑤	10...30 V DC	Power supply (jack) for external power supply
⑥	Service	Button

RS 485/422 with MAM-GM24		
③	COM2 (RS485/RS422)	5-pin screw terminal configurable over DIP switch (only MAM-GM24)

Tab. 3-1: Description of the connectors of the Alarm Modem GSM

You find the outline of the respective variant in chapter 10.

3.1.2 Alarm Modem 56k

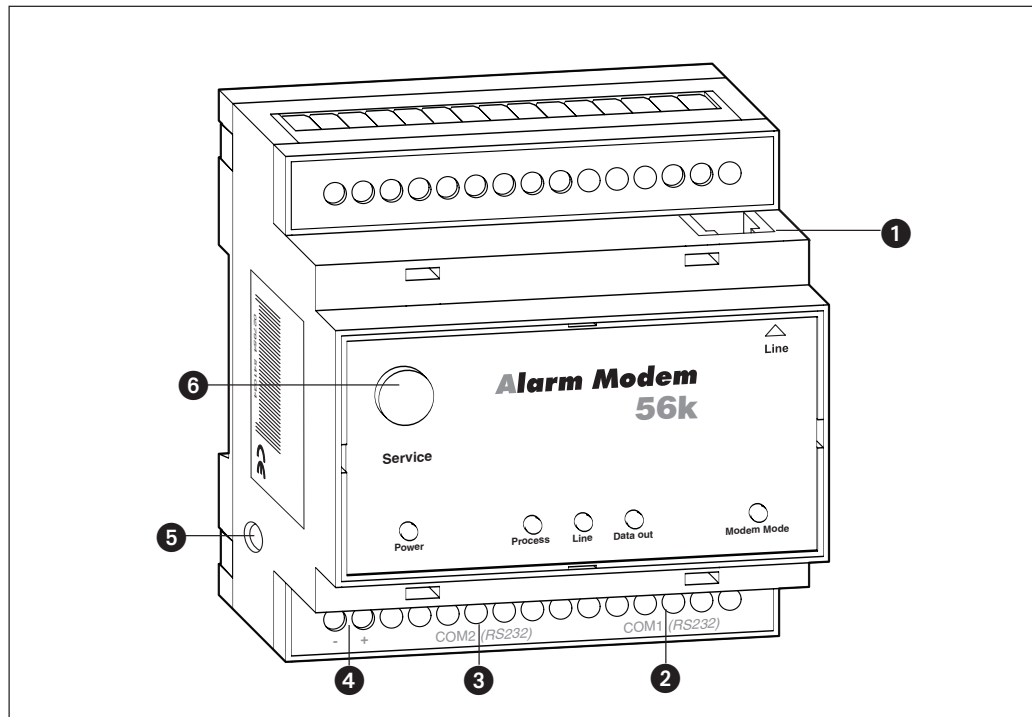

Fig. 3-2: Overview of all connectors of the Alarm Modem 56k

No.	Marking	Meaning
1	Line	Telephone jack RJ11
2	COM1 (RS232)	9pin D-Sub jack
3	COM2 (RS232)	9pin D-Sub plug (only MAM-AM20)
4	10...30 V DC	Power supply (2 screw terminals)
5	10...30 V DC	Power supply (jack) for external power supply
6	Service	Button

RS 485/422 with MAM-AM24		
3	COM2 (RS485/RS422)	5-pin screw terminal configurable over DIP switch (only MAM-AM24)

Tab. 3-2: Description of the connectors of the Alarm Modem 56k

You find the outline of the respective variant in chapter 10.

3.2 Meaning of the LEDs

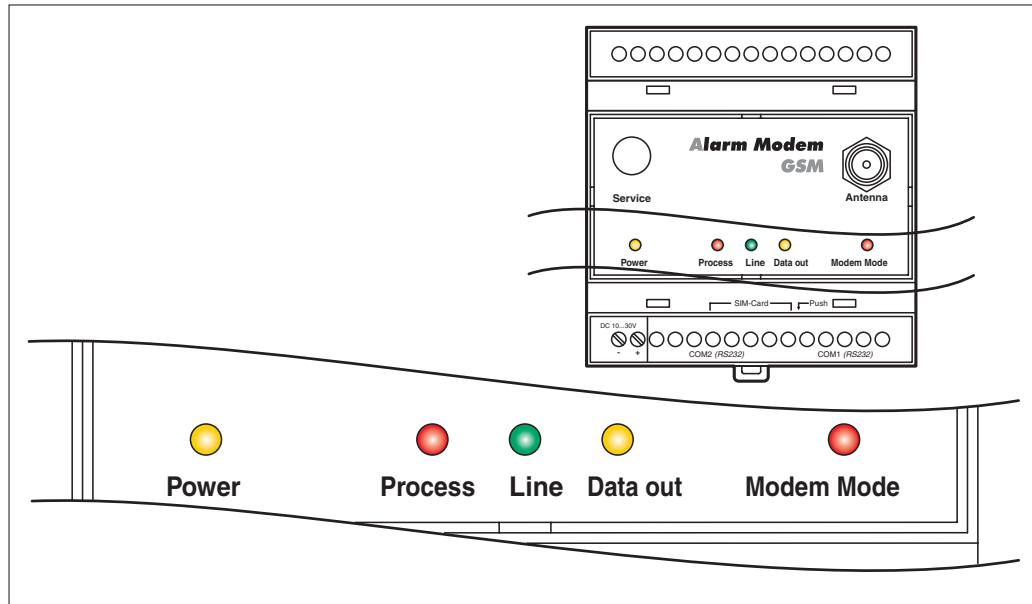

Fig. 3-3: LEDs on the modem

LED	Status	Meaning
Power (yellow)		Device operational
		No power supply
Process (red)		Processing in progress: message generation, variable changes etc.
		Normal operation, no processing in progress
Line (green)		Connection present
		Modem is not logged onto the GSM network
		Modem is logged onto the GSM network. LED flashes every 2 s (only GM series).
Data Out (yellow)		Message ready to send waits inside the device
		No message in outbox
Modem Mode (red)		TiXML Mode standard mode for the Mitsubishi Alarm Modem.
		Modem Mode (device usable as generic modem via COM1)
		Transparent Mode (device provides transparent connection)

Tab. 3-3: Meaning and function of the LEDs

NOTE

Operations in progress but messages cannot be sent until Modem Mode is terminated (see section 7.5.5).

3.3 Mounting

Mount the modem by pushing or snap fitting it onto a DIN rail (top-hat rail 35 mm).

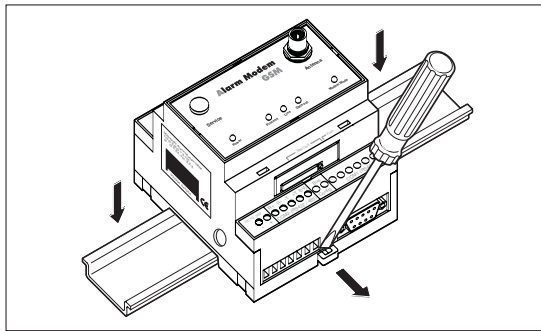

Fig. 3-4:
Pull out the black tab on the device using a screwdriver and so the device can snap fit to the DIN rail. You can remove the device from the rail in the same way. Ensure that the retaining mechanism of the modem snaps cleanly and securely into the DIN rail.

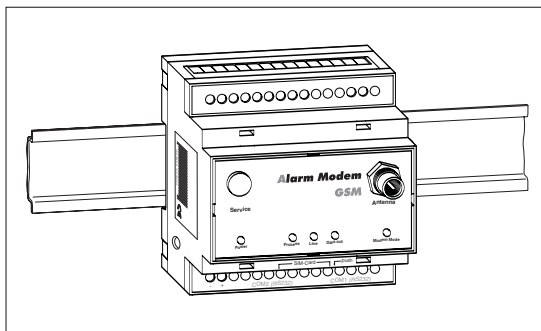

Fig. 3-5:
Modem mounted on the DIN rail



ATTENTION:

- *The device must only be used in rooms that are dry and clean. Protect the device from humidity, water splashes or heat.*
- *Do not subject the device to severe vibration.*



DANGER:

- *The device must not be used in environments containing flammable gases, fumes or dust.*

3.4 Connecting the GSM antenna (only GM series)

First of all find a suitable location for mounting the GSM antenna outside of the control cabinet. In order to find a suitable location with a good reception quality you may use the software MX Mitsubishi Alarm Editor to display the signal quality.

Screw the antenna plug into the antenna socket on the front of the modem.

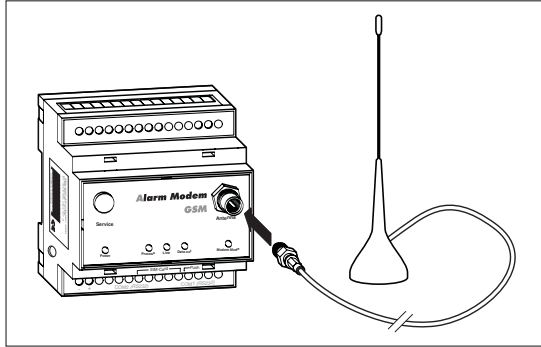

Fig. 3-6:

When fitting the antenna plug ensure that it is seated correctly. It should be possible to turn the threaded nut easily.

NOTE

Standard GSM antennas with an FME plug can be used. The GSM antenna is not supplied with the modem and can be ordered separately.

Ensure that you buy an antenna with the correct frequency range for your mobile communications network. Further information on this is provided in the Appendix of this manual in section 10.4, Mobile communication networks in Europe, USA and worldwide.

If the length of the antenna cable is not sufficient for your requirements you can use a suitable extension cable purchased as an accessory from a GSM outlet. Take into account the attenuation of these cables that will reduce the antenna gain and observe the relevant specifications of the manufacturer.

3.5 Inserting the SIM card (only GM series)

To insert the SIM card in the modem, open the SIM card holder on the Mitsubishi Alarm Modem by pressing the small button on the right of the holder with a pen or a pointed object.

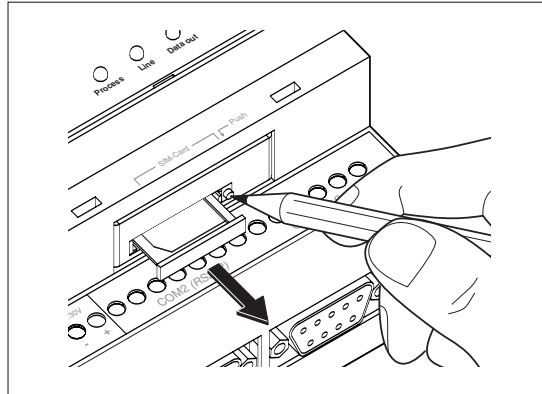

Fig. 3-7:
Push down the button until the card holder is released

You can now carefully pull out the card holder and insert your SIM card. Then push the SIM card holder back into the modem until it snaps into position.

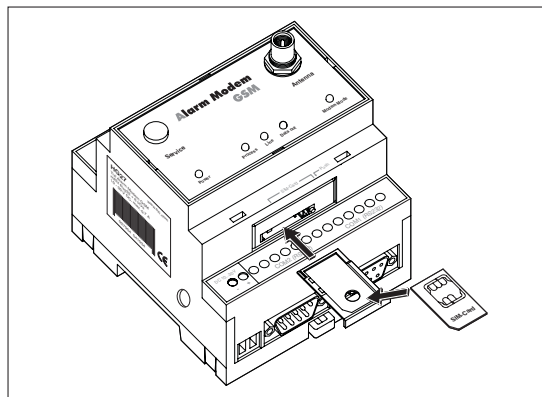

Fig. 3-8:
Insert the SIM card with the contact side facing upwards and ensure that the card is seated correctly in the recess. Then push the SIM card holder back into the modem until it snaps into position.

NOTES

If you are not using a new and unused SIM card, use a mobile phone to ensure first of all that the SIM card does not contain any saved SMS messages (read or unread) as this may otherwise cause malfunctions.

Avoid touching the contacts of the SIM card as electrostatic discharge may otherwise damage it.



ATTENTION:

The SIM card should only be removed when the modem is in power-off state. The SIM card may become unusable if this warning is not observed.

3.6 Connection to the Telephone Network (only AM series)

Connection to telephone network (PSTN) is established via the included telephone cable and the "Line" jack of the MAM.

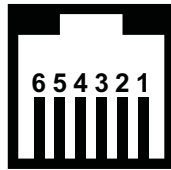

1 - b2 **Abb. 3-9**
2 - W *The Mitsubishi Alarm*
3 - a *Modem supports the a/b*
4 - b *leads (3 and 4).*
5 - E
6 - a2

To get access to your Mitsubishi Alarm Modem, the telephone number of the connection used must be known.

3.6.1 Testing the Telephone Connection

In order to check the telephone number of the connection used, plug a telephone into the appropriate socket and dial the number by another telephone, or from a mobile. If the telephone at the appropriate socket rings, the number is correct.

In order to check if the telephone connection supports the CLIP feature, dial from the appropriate connection to another telephone. If the calling number is shown at the called party's end, the CLIP feature is supported.

If this is the case, your Mitsubishi Alarm Modem may send messages via phone, may be called for remote connections or even may trigger events by the calling number transmitted.

3.6.2 The CLIP Feature

Additionally, for triggering events by calling number identification, the CLIP feature (recognizing incoming call numbers) of the connection used must be enabled. For details on this, please contact your telephone service provider.

3.6.3 Telephone Exchange System

When connecting to a telephone exchange (PABX), take care if an outside line prefix is necessary, and check with your telephone system documentation if the CLIP feature is supported.

4 Interfaces

The serial interfaces COM1 und COM2 are to connect a PC, a PLC or other devices.

NOTE

The type and number of interfaces available depend on the type of modem being used. (see section 2.6 and 10.6).

4.1 COM1 – RS232 (Jack)

The RS232 interface COM1 (9-pole D-Sub socket) is provided on all Mitsubishi Alarm Modem models. It is primarily used as a programming interface for connecting a PC. A standard 1:1 serial cable can be used for this (not supplied)

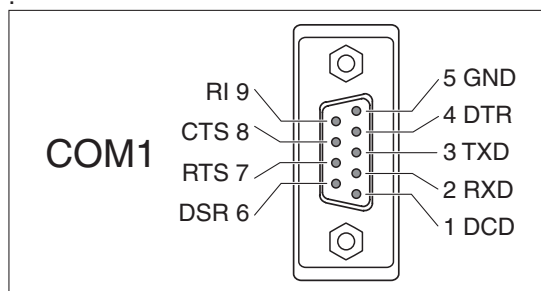

Fig. 4-1:

The COM1 port has the same assignment as a standard modem with an RS232 socket.

4.2 COM2 – RS232 (Plug)

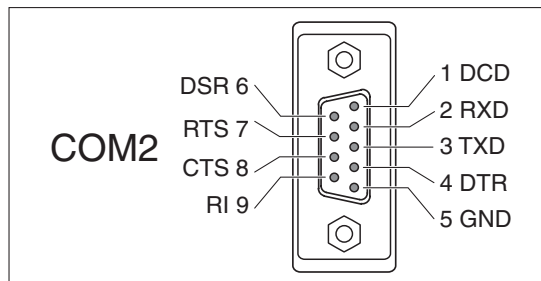

Fig. 4-2:

The assignment of the COM2 (plug) is the same as that of a COM port on the PC.

NOTE

As most PLCs require the use of a special serial programming cable, the programming cable of Mitsubishi concerned should be used in all cases.

4.3 Mitsubishi Alpha XL and Mitsubishi FX at RS232

4.3.1 Alpha XL

The Mitsubishi Alpha XL is to be connected to the COM ports of the Mitsubishi Alarm Modems (MAM):

- directly by the "AL2-GSM-CAB" cable to COM1
- by the "AL2-GSM-CAB" cable and the "Red Adapter" (see chapter 10.3) to COM2

4.3.2 Mitsubishi FX1S, FX1N, FX2N, and FX2NC

The Mitsubishi FX is to be connected to the COM ports of the Mitsubishi Alarm Modems:

- at the Mini-DIN jack of the FX: by the "SC-09" cable and the "Blue Adapter" (see chapter 10.3) to COM1
- at the Mini-DIN jack of the FX: directly by the "SC-09" cable to COM2
- at the RS232-BD of the FX: directly by a serial cable (1:1) and the "Brown Adapter" (see chapter 10.3) to COM1
- at the RS232-BD of the FX: by a serial cable (1:1) and the "Red Adapter" (see chapter 10.3) to COM2

4.4 RS485 / RS422

The MAM-GM24 and MAM-AM24 device is provided with an RS485/422 interface for connecting two-wire and four-wire bus systems to the Mitsubishi Alarm Modem. The interface is provided as a 5-pole screw terminal strip on the device. This interface is not galvanically isolated.

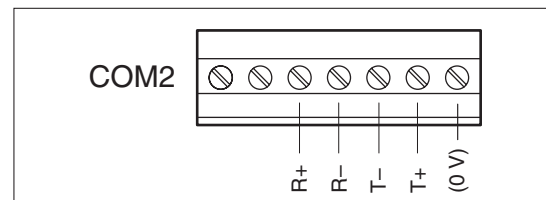

Fig. 4-3:
Terminal assignment of the RS485/422 interface (view from top)

NOTE

Twisted pair cables are recommended. In RS422 operation and with 4-wire RS485 operation 2 twisted pair cables should be used.

Access to the DIP switches

A DIP switch is provided for selecting the operating mode at the RS485/422 interface. This is located on the right of the COM2 connection terminal and is accessible after the cover is removed.

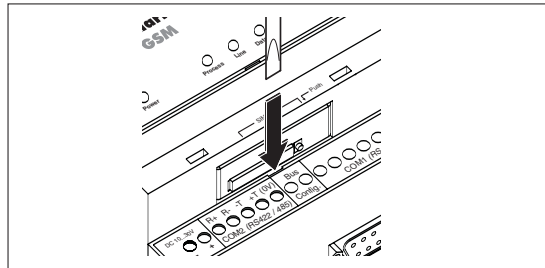

Fig. 4-4:
Put a screwdriver (blade width 3mm) into the small slit and gently rotate the screwdriver.

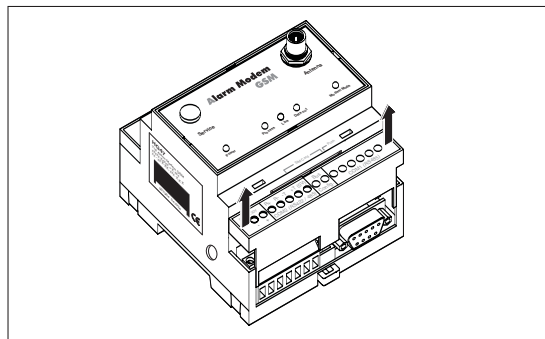

Fig. 4-5:
The terminal cover snaps off from the case with an audible click and may be removed.

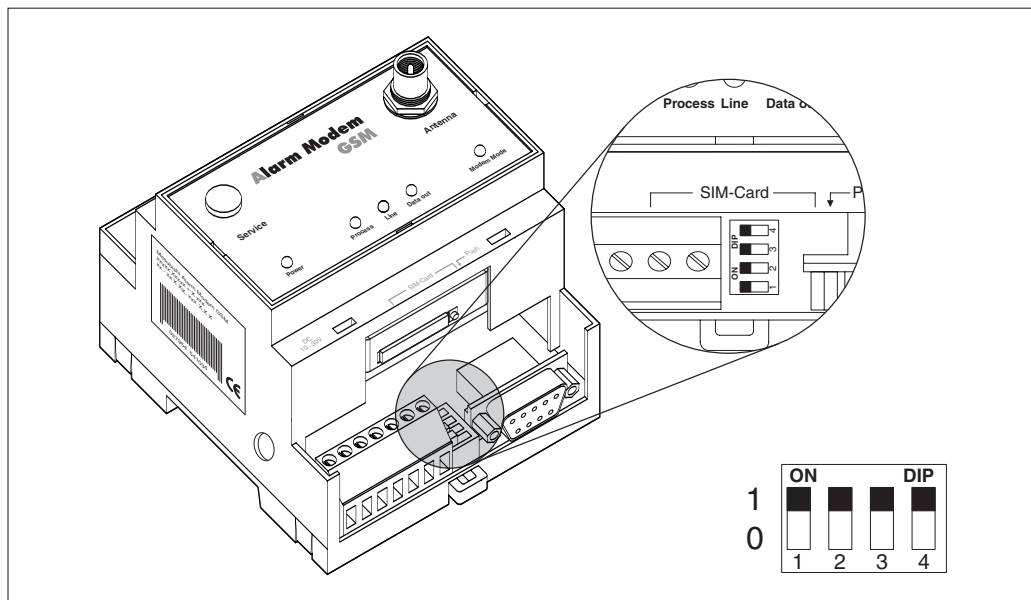

Fig. 4-6: Position of the DIP switches under the terminal cover

Setting the operating mode on the DIP switch

Operating mode	DIP 1	DIP 2	DIP 3	DIP 4	DIP
Two-wire RS485 with termination	1	1	1	1	1111
Two-wire RS485 without termination	0	0	1	1	0011
Four-wire RS485 without termination	0	0	0	0	0000
Four-wire RS485 with termination of receive cable	1	1	0	0	1100
RS422	0	0	0	0	0000

Tab. 4-1: Setting the operating mode on the DIP switch

NOTE

RS485 stipulates that the cables should be terminated at both ends of the transmission section. The termination prevents signal reflections in the cables and in times of no data transmission, enforces a defined idle state on the bus. This termination can be implemented using, for example, specific resistors at the screw terminal. It can also be implemented via the DIP switches on the Mitsubishi Alarm Modem.

RS422 Connection

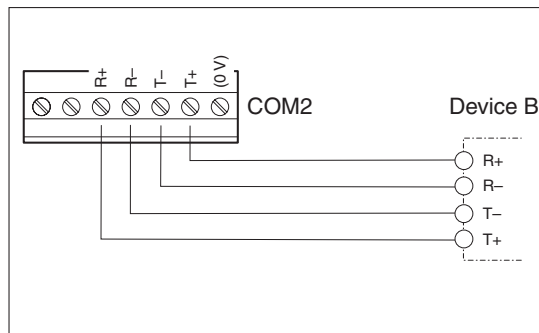

Fig. 4-7:

The **receiving lines** are to be connected to R+ (other end T+) and R- (other end T-), the **sending lines** to T+ (other end R+) and T- (other end R-) according to the opposite sketch.

RS485 2-wire connection (2-wire bus system, half-duplex)

In this operating mode, transmit cables and receive cables are interconnected. If the Mitsubishi Alarm Modem is installed at the beginning (first station) or end (last station) of the bus system, the bus system must be terminated by setting the DIP switches accordingly.

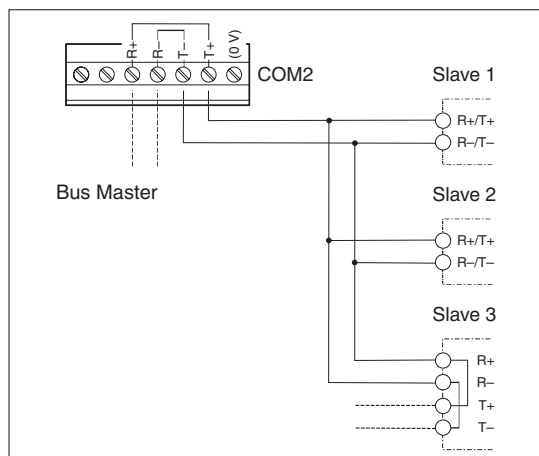

Fig. 4-8:

The twisted pair cable is to be connected to T+ to T+ or R+ and for T- to T- or R- according to the opposite sketch.

RS485 4-wire connection (4-wire bus system, full-duplex)

The terminals of the 2 twisted-pair cables are wired in the same way as for the RS422 connection. Both twisted-pair cables must be terminated if the Mitsubishi Alarm Modem is installed at the start or end of the bus cables. The termination of the receive cables is activated via the DIP switches. The transmit cables must be terminated externally (see figure arrow).

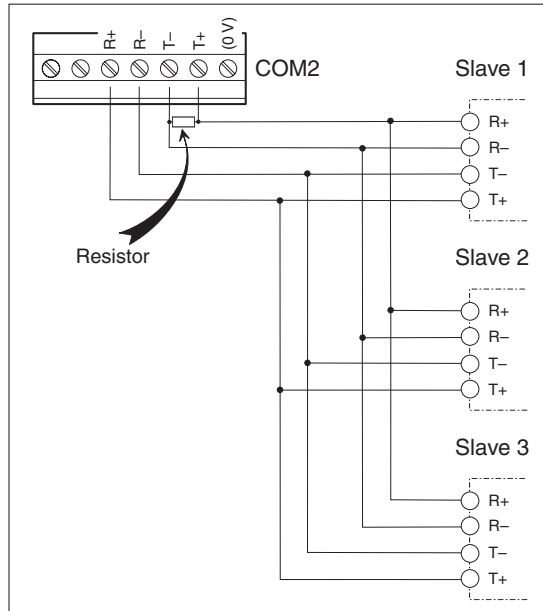



Fig. 4-9:
The twisted pair cables are to be connected according to the opposite sketch. For termination of the sending line, put a resistor (120 Ohm/0,5 W) between the T+ and T- terminals.



ATTENTION:
Always ensure that the end devices are terminated correctly.
Incorrect or missing termination may give rise to communication faults.

4.5 Mitsubishi FX at RS485/422

The Mitsubishi FX is to be connected via the optional RS485-BD or RS422-BD to the optional COM2 of the Mitsubishi Alarm Modem, using 5-wire twisted pair cable. The Alarm Modems DIP switches 3 and 4 must be set to OFF therefore. Perhaps the termination is to be set via DIP switches 3 and 4. More information on these DIP switches are to be found in chapter 4.4 of this manual.

The wiring shall become clear by this depiction:

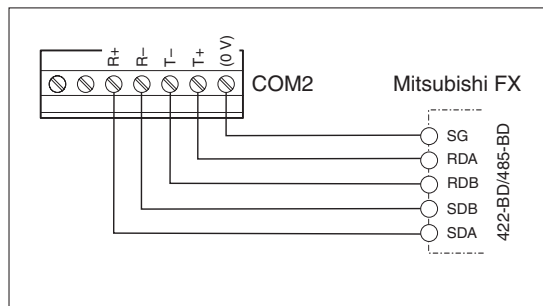

Fig. 4-10:
Connection of the modem at the Mitsubishi FX via the optional RS485/422-BD

5 Power supply

After all installation steps are completed, switch on the power supply to the Mitsubishi Alarm Modem. The modem got two power supply connectors: Two screw terminals and a power supply jack (pin diameter 2,1 mm, inner diameter 6 mm).



ATTENTION:

Power $U = 10 - 30\text{VDC!}$

Ensure the correct polarity of the power supply terminals.

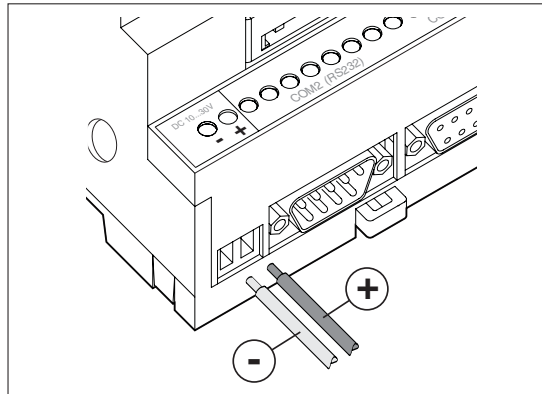

Fig. 5-1:

Ensure that the screws are seated correctly.

NOTES

In order to avoid the interference from power supply units or other interference sources, DC cables should not be installed in the direct vicinity of AC cables.



ATTENTION:

- **Use leads with sufficient diameter only.**
- **Do not use flexible leads with soldered tips.**
- **Watch the polarity and currency parameters (10 ... 30VDC, max. 0.7A, Power supply jack: pin = positive)**
- **In order to avoid damages, fasten the terminal screws with a torque momentum of 0.5 ... 0.6Nm.**
- **Nutzen Sie die Netzgeräte-Einbaukupplung, vergewissern Sie sich, dass der Stecker einen Stiftdurchmesser von 2,1 mm und einen Innendurchmesser von 6 mm hat.**
- **Wiring must be done wit power off only.**

6 Operation

Once all installation steps have been completed, you can start operating the Mitsubishi Alarm Modem.

Self-test after power up

The Mitsubishi Alarm Modem carries out an extensive self-test after the power supply is switched on. All the LEDs will switch on for test purposes and all three types of memory are checked. The memory test is also carried out automatically with every power up.

Memory test

This tests the internal memory with RAM, program memory (Flash ROM) and the file system in the user memory (Flash). On basic models (2 MB for the user memory) this test lasts approx. 12 seconds. If memory expansions have been fitted, the time can be considerably longer depending on the size of memory in use.

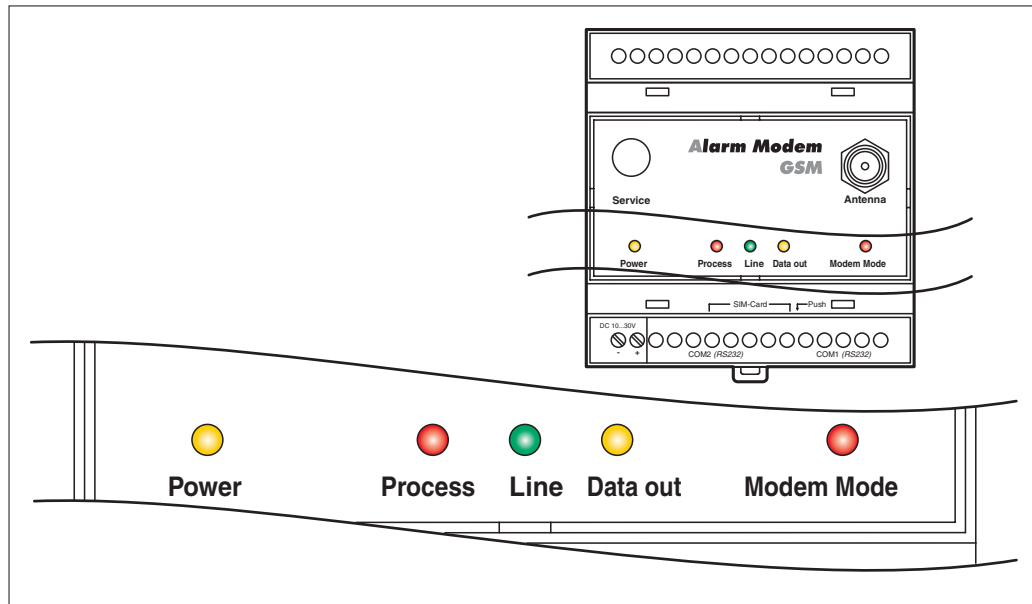

Fig. 6-1: LEDs on modem

Power (yellow)	Process (red)	Line (green)	Data Out (yellow)	Modem Mode (red)	
●			●		Starting Self-test
●	●	●	●	●	Testing LEDs
●			⏏ flashes		Testing memory
●					Modem is fully operational
					Duration: approx. 12 sec

Tab. 6-1: LEDs during the self-test

Mitsubishi Alarm Modem is operational

The device is operational once the self-test is completed and it has “started working”.

Line-LED when functioning correctly (only GM series)

The Mitsubishi Alarm Modem GSM is logged in if the green Line LED flashes at regular intervals.

NOTE

If the Mitsubishi Alarm Modem is being commissioned for the first time or after a complete delete operation (Factory Reset, section 10.2.3), a project must be loaded with the correct PIN for the SIM card. Note the following instructions in section 7.1 (Initial configuration).

7 Configuration and projects

7.1 Initial configuration

You can regard a Mitsubishi Alarm Modem (MAM) in the same way as you would consider a PC with an operating system and many communication programs. After the initial power up, the task memory is empty and the MAM “doesn’t know” what it is meant to do. It has to be configured first of all and assigned a task. The task definition for the MAM with all the relevant data is called a project and is saved in a TiXML project file. These points are explained in the following paragraphs.

7.2 Loading projects in the MAM

You can create projects with a number of different user programs available, e.g. MX-Mitsubishi Alarm Editor MX-MAE (see chapter 8.1). The required parameters can be entered easily on the PC and then saved on the hard disk of the PC as a TiXML project file. The PIN of the SIM card is also entered in the software and in the project file (only GM series). The project must then be loaded onto the Mitsubishi Alarm Modem via a serial interface.

The device is now functional as a stand-alone device (i.e. without a PC) and can be used, for example, to monitor PLCs.

7.3 Loading projects remotely on the MAM

Once a functional configuration has been loaded on the MAM, this can also be modified or transferred by remote dial-in. Every reconfiguration (remotely or locally) can be protected from unauthorized access by means of a password and user name. Refer to section 8.2, Secure Login, for further information.

NOTE

| The contents of chapter 7.4 applies only to the GM series.

7.4 Operating the GSM Modem

As with a mobile phone, the PIN of the SIM card has to be entered in order to correctly configure the Mitsubishi Alarm Modem for GSM operation. The MAM can only log in automatically and become functional if the correct PIN has been entered. Refer to the documentation of your mobile network supplier for the PIN. Once the SIM card has been inserted in a mobile phone, the PIN can also be modified there.

7.4.1 PIN entry with MX-MAE software

When using MX-MAE software, the PIN can be entered when you are creating the project.

7.4.2 PIN OK, network available, MAM logged in

The MAM logs in like a normal mobile phone if the PIN that is entered in the project for the SIM card inserted is correct, and network reception for the respective provider is available. The Line LED will then flash at regular intervals.

7.4.3 PIN OK, no network, MAM not logged in

The MAM cannot be logged in if there is no network reception available for the provider concerned, even if the PIN that has been entered in the project for the inserted SIM card is correct. The Line LED will not flash and will remain off.

The Line LED will flash again, if the reception quality is sufficient, by using a stronger antenna for example.

7.4.4 PIN incorrect, MAM not logged in

If the PIN that has been entered in the project for the inserted SIM is incorrect, the MAM will not be able to log in, and will indicate this by causing the Process, Line and Mail-out LEDs to flash.

The same will happen if after initial commissioning or after a factory reset no project and therefore no PIN is loaded onto the MAM.

Ensure that a valid SIM card was inserted, that it is seated correctly and the PIN used is correct.

7.4.5 SIM card disabled, entry of the SUPER PIN

If the PIN was entered incorrectly 3x, the SIM card will be disabled. The card can be unlocked again by entering the SUPER PIN. To do this, insert the disabled SIM card into a mobile phone and enter the SUPER PIN and PIN as described in the operating instructions. Once the mobile phone has logged in properly with the SIM card, the unlocked SIM card can then be reinserted in the Mitsubishi Alarm Modem.

7.4.6 SIM Card Service Center

Additionally, use a mobile phone to check if the SMSC (Short Message Service Center) number is stored on the SIM card. If not so, sending SMS from the Mitsubishi Alarm Modem will not be possible. In that case, contact your mobile service provider for details on how to store this number on the SIM card.

7.4.7 Caution in border regions: Logging in abroad

Like a mobile phone, the MAM also searches for the strongest mobile network provider in the area. In areas up to 10 kilometers from international borders, this may be a foreign mobile phone provider. Considerably higher costs may be incurred if the MAM logs into one of these (roaming). Moreover, problems may also occur with the sending of SMS messages and e-mails. You can prevent the logging into "foreign" networks by allocating a "home network" to the SIM card.

7.5 Operating modes: Modem Mode and TiXML Mode

TiXML Modus

Mitsubishi Alarm Modems (MAM) can handle a wide range of tasks automatically. These tasks are written and configured in TiXML, a variant of the XML standard. This operating mode is called TiXML Mode.

7.5.1 Alarm Editor MX-MAE activates the correct mode

If you always configure the Mitsubishi Alarm Modem with the MX-MAE software, you do not have to worry about the two modes, as this tool will automatically activate the correct mode (TiXML Mode). You can skip the rest of this section and continue reading at the chapter 8 "Software".

7.5.2 Using MAM without MX-MAE

Only if you are using the MAM without MX-MAE, for example:

- because you wish to use the MAM for other programs just as a simple modem,
or
- because you wish to work with a terminal program such as Windows Hyperterminal,
or
- because you are programming a PLC that is required to send commands to the MAM,
you will have to take the difference between TiXML Mode and Modem Mode into account.

7.5.3 TiXML Mode

The task definition for TiXML Mode is loaded on the MAM by means of a project file (the configuration file). These kinds of projects can be created with different software tools (e.g. MX-MAE). MX-MAE will automatically switch a MAM to the correct mode, i.e. TiXML Mode. The user does not have to worry about this.

After power on a MAM will always be in the last activated mode (TiXML Mode or Modem Mode). The device can be set to the TiXML Mode with a factory reset (refer to section 10.2.3) so that it can immediately start with the automatic tasks, e.g. send alarms in the event of faults.

7.5.4 Modem Mode (also AT mode)

Normal modems (AT modems) can do nothing "on their own" and are controlled by means of simple communication commands, e.g.:

- "Dial a telephone number and connect me" and
- "Terminate the connection and hang up."

These modems always require a PC or a communication controller that executes the tasks since they have no "intelligence" of their own and do not recognize any Internet protocols.

For greater compatibility, however, Mitsubishi Alarm Modems can also be switched to operating like a normal AT modem. This is called Modem Mode, in which the red Mode LED will be lit.

PIN entry without MX-MAE (only GM series)

If you are not using MX-MAE, you must enter the PIN or SUPER PIN with TiXML or AT commands by means of a terminal program. Therefore refer to the TiXML manual.

7.5.5 Activating/deactivating Modem Mode

In Modem Mode, a MAM operates like a normal modem and establishes connections with the conventional AT command: "ATDT 0123456789".

The MAM must, however, be switched beforehand from TiXML Mode to Modem Mode.

Activating Modem Mode

The following TiXML command can be used to switch the device to Modem Mode via COM1:

```
AT+TMode="ModemMode"
```

The device will send back the following acknowledgment:

```
OK
```

Once this command has been sent, the MAM will only recognize AT commands and will respond to these, for example, with OK.

Deactivating Modem Mode, activating TiXML Mode

If the device is in Modem Mode, it can be switched back to TiXML Mode using the following AT command:

```
AT+T Mode="TiXMLMode"
```

Response from MAM:

```
OK
```

Once this command has been sent, the MAM will only recognize TiXML commands and no AT commands.

**ATTENTION:**

The MAM cannot send or receive messages if the red Modem Mode LED is lit. Although the MAM will continue processing the tasks, message jobs cannot be executed until the modem is free again and the Modem Mode LED is off.

NOTE

AT commands are only processed by Mitsubishi Alarm Modems in Modem Mode.
TiXML commands are only recognized in TiXML Mode.

7.5.6 Sending commands to the MAM

Any terminal program, such as Windows Hyperterminal, can normally be used for entering and transferring TiXML and AT commands.

The following COM port settings are recommended:

115.200 Bit/s and 8N1 (8 data bits, no parity, 1 Stop bit, Hardware Handshake)

8 Software

8.1 MX Mitsubishi Alarm Editor MX-MAE

MX-MAE is a user-friendly Windows software for configuring MAM functions such as alarms and messages, as well as the reception/sending of messages and the reading of logged data.

You use the mouse to configure the recipients, messages and PLC variables for alarm messages. MX-MAE also allows you to dial into a remote MAM from a PC via a modem, fixed network or mobile phone connection and to configure it remotely.

In this way, MX-MAE allows you to access a remote device exactly as if it was a local device, and with the same range of functions.

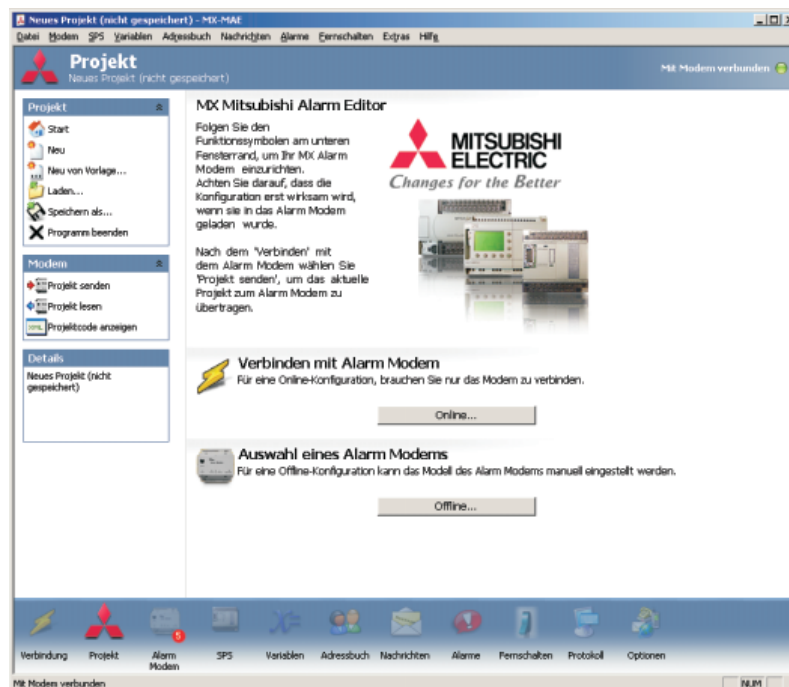

Fig. 8-1: Mitsubishi Alarm Editor MX-MAE

8.2 Secure Login: Access Protection

Mitsubishi Alarm Modems can be protected against unauthorized access. To do this, the names and passwords of authorized users are defined in the software tool (MX-MAE) during the configuration. In this way, only authorized users are able to modify or read the MAM configuration or access the Mitsubishi Alarm Modem locally or remotely.

If the Secure Login data is “forgotten”, the device must undergo a factory reset and restored to its original default settings. This is the only way to delete the entire configuration that also contains the Login-Data (see section 10.2.3). The MAM must then be reconfigured with a project and a Secure Login.

8.3 Remote Access

If you are using a PLC programming software to configure and control your PLC, you can also make use of its functions remotely by software MX-MAE. To do this, the PLC must be connected to a serial interface on the MAM.

MX-MAE establishes a connection to the remote Mitsubishi Alarm Modem and uses its RS232 interface to the PLC as a virtual local COM interface for your PC. This transparent modem connection allows you to access your PLC using your standard software as if it was connected directly to your PC. You can then carry out any required task remotely.

9 Communication with a PLC

Mitsubishi Alarm Modems can communicate with a PLC in two different ways:

- The Mitsubishi Alarm Modem can speak the language of your PLC.
Technical feature: The required **PLC driver** is integrated in the Mitsubishi Alarm Modem.
- The Mitsubishi Alarm Modem and the PLC can speak a joint language.
Technical feature: Mitsubishi Alarm Modem and PLC use the **same protocol**, e.g. Modbus.

9.1 PLC driver in the Mitsubishi Alarm Modem

Mitsubishi Alarm Modems can communicate with the relevant PLCs using their protocols without having to load a program, driver or function block into the PLC concerned. They then have direct access to all variables, markers and I/O on the PLCs.

The Alarm Modem can easily be set with parameters using the software MX-Mitsubishi Alarm Editor.

These PLCs are supported:

Alpha XL and MELSEC FX1S/1N, FX2N/2NC

For MAM-PLC communication, the internationally standardized fieldbus system Modbus (ASCII and RTU) may also be utilized.

10 Appendix

10.1 Technical data of the MAM series

Main functions

Features	Data
Alarm and fault indication unit	Automatic generation and sending of fault messages from message templates and actual values (from PLC or Mitsubishi Alarm Modem). Up to 100 events can be defined to trigger actions (depending on of time requirements). Address book with up to 100 addresses, max. 100 message texts, max. 100 alarms.
Acknowledgment	Acknowledgment option for an alarm and triggering of an alarm cascade if the acknowledgment is not received in the time specified. Acknowledgment possible by SMS and Express E-Mail.
Alarm cascade	Several levels of alarm actions and recipients for when alarm messages are not acknowledged in time. Alarm actions can be sending SMS, e-mail, faxes or Express E-Mails.
Event	Event, such as: button actuation, fault, incoming call, PLC communication aborted, alarm acknowledgment. All actions in the Mitsubishi Alarm Modem are event-triggered.
Fax	Send messages as fax (text)
SMS	Send and receive SMS messages
E-Mail	Send e-mails (SMTP)
Express E-Mail	Send and receive e-mail via direct telephone connections. Secure e-mail transfer without Internet with immediate sending to the recipient.
Remote switching	Remote switching of outputs or changing of variable values of the connected PLCs by sending switch commands as SMS or Express E-Mail to the Mitsubishi Alarm Modem. Switching also by dialing with caller identification (CLIP) without connection establishment, i.e. without telephone charges (country dependant).
Teleservice	Configuration of the Mitsubishi Alarm Modem and a connected PLC by remote dial-in via modem.
Caller identification	Switching with CLIP feature (Calling Line Identity Presentation), i.e. call number identification.
Security	Local and remote configuration can be protected against unauthorized access by login and password.

Tab. 10-1: Main functions

System architecture

Features	Data
CPU	32-bit RISC Processor
Program memory	2 MB Flash-ROM, 1 MB SRAM
Data memory	2 MB Flash Memory onboard, non-volatile
Expansions	16 MB, 32 MB, 64 MB Flash memory modules
System clock	Real-time clock, battery-backed

Tab. 10-2: System architecture

Technical specifications GM series

Features		Data
Network	Type	GSM/GPRS Class 10, Dual Band 900/1800 MHz (GSM series)
Antenna		FME plug (male), coaxial, Impedance: 50 Ohm, Reception frequency: 925 ... 960 MHz/ 1805 ... 1880 MHz Transmission frequency: 880 ... 915 MHz/ 1710 ... 1785 MHz Output: 2 W (900 MHz) 1 W (1800 MHz)
Data transmission		300 bps – 14,4 kbps async., transparent/non transparent ITU-T (V.21,V.22, V.22bis, V.26ter, V.32, V.34, V.110)
Fax transmission		Fax Group 3 / Class 1 and 2. 2400 bps – 14,4 kbps ITU-T (V.17, V.29, V.27ter) Data compression: MNP2, V.42bis

Tab. 10-3: Technical specifications GM series**Technical specifications AM series**

Features		Data
Network		Analog connection (PSTN, a/b Interface), RJ11
Data transmission		300bps – 56kbps, ITU-T (V.90, V.34+, V.32bis, V.32, V.22bis, V.22, V.21), Bell 212A, Bell103
Fax transmission		Fax G3 / Class 1, 2400bps – 14,4kbps, ITU-T (V.17, V.29, V.27ter, V.21 ch2)
Error Correction/ Data Compression		V.42 / MNP 2-4, V.42bis / MNP5

Tab. 10-5: Technical specifications AM series**Firmware**

Features		Data
Operating system		Commercial RTOS (real-time multitasking operating system) with C++ abstraction layer
File system		Commercial DOS compatible Flash file system C++ abstraction layer
External control protocol		TiXML: simple, text-based XML-like protocol for modem configuration. External applications can create events / alarms by sending event commands.

Tab. 10-4: Firmware

The type and number of interfaces depends on the model.
Refer to the overview in section 2.6.

Serial interfaces

Interface		Data
RS232		To ITU-T V.24, V.28, Hardware-Handshake
	COM1	D-Sub 9-pole, Socket FIFO 16550, max. 230.400 bps, Signals: DTR, DSR, RTS, CTS, DCD, GND, RI, RxD, TxD Transmission distance 15m
	COM2	D-Sub 9-pole, plug, otherwise as for COM1
RS485/422		To EIA/TIA-485
	COM2	5-pole screw terminal for T+, T-, R+, R-, 0 V max 1.5 Mb/s, not isolated Termination integrated, activated via DIP switches Transmission distance max.1200 m depending on the transmission rate, bus system and cable type

Tab. 10-6: Serial interfaces

General Data











Feature		Data
Power supply		10 – 30 V DC, max. 0.7 A, screw terminal 2.5 mm ² und power supply jack (pin diameter 2 mm, inner diameter 6 mm).
LEDs		Power, Process, Line (connection), Data out, Modem Mode
Operating elements		Button
Housing/mounting		DIN-Rail Casing, for rail 35mm to EN50022, vertical or horizontal
Conformity	GM series	CE, EN 55022 (9:2003), EN 55024 (10:2003) EN 301489-1/7 (2000 GSM) EN 60950
		3GPP TS 51.010-1 (9:2002, v5.0.0.0) GCF-CC (10:2002, v3.8.1)
	AM series	CE, EN 55022 (9:2003), EN 55024 (10:2003), EN 60950
		R&TTE-Policy TS 103021
Temperature range	Operation	0 ... +50 °C
	Storage	-30 ... +70 °C
Permissible air humidity		5 to 95 % relative humidity, non-condensing
Degree of protection		IP20
Degree of pollution		Pollution degree 2
Dimensions		Width: 88 mm x Height: 57 mm x Depth: 91 mm (without antenna connection)
Weight		240g

Tab. 10-7: General data

10.2 LEDs, Reset, Update, Error Diagnostics





10.2.1 LEDs on restart

The Alarm System runs through a memory test after the power supply is switched on, after a factory reset or after new firmware is installed.

Power (yellow)	Process (red)	Line (green)	Data Out (yellow)	Modem Mode (rot)	
					Start self-test
					Test of all LEDs
			 flashes		Memory test
					MAM is operational.
					Duration of self-test approx. 12 s

Tab. 10-8: LEDs on restart

10.2.2 LEDs in the event of faults (only GM series)

Process (red)	Line (green)	Data Out (yellow)	
 flashes	 flashes	 flashes	Fault when accessing the GSM module This may be due to an incorrect PIN, no project loaded in the Mitsubishi Alarm Modem or a fault in the GSM module.
	 off		No network, poor reception quality The modem is not logged in if the GSM network is not available or the reception quality is too poor. Check the connection and the positioning of the antenna.

Tab. 10-9: LEDs in the event of faults

10.2.3 Factory Reset

A factory reset deletes all the data stored in the Mitsubishi Alarm Modem and overwrites them with factory settings. Your GSM settings (PIN) are retained.

Procedure:

- ① Switch off the Mitsubishi Alarm Modem
- ② Press the Service button and keep depressed
- ③ Switch on the Mitsubishi Alarm Modem and wait for the Power LED to flash
- ④ Release the Service button momentarily and
- ⑤ Press again until the Power LED visibly flashes at a faster rate
- ⑥ Release the Service button















ATTENTION:

A factory reset deletes the configuration!



















Remember that this operation will delete any configuration contained in the modem.

LEDs during factory reset and restart

Power (yellow)	Process (red)	Line (green)	Data Out (yellow)	Modem Mode (red)		Duration
 flashes					Service button pressed upon power-on	1–2 s
 flashes rapidly					Service button pressed again, until Power LED flashes somewhat faster	1–2 s
					Test of all LEDs	
			 flashes		Memory test, formatting data memory (complete deletion)	25 s
					MAM is operational	
Total duration						approx. 30 s

*Tab. 10-11: LEDs during Factory Reset and restart***10.2.4 Firmware-Update**

A new firmware can be loaded onto the Mitsubishi Alarm Modem using an upload tool. In this case the LEDs of the Mitsubishi Alarm Modem will light up as follows:

Power (yellow)	Process (red)	Line (green)	Data Out (yellow)	Modem Mode (red)		Duration
					MAM is operational.	
 flashes					Start of update	2s
					MAM waiting for commands.	
		 flashes	 flashes		After start of update: Transfer of firmware	ca. 250 s
	 flashes				Possibly during the update: Processing of transferred firmware in MAM	
					Test of all LEDs	
			 flashes		Memory test, formatting data memory (complete deletion).	25 s
					MAM is operational.	
Total duration						approx. 4 min 40 s

Tab. 10-10: LEDs during Firmware-Update

The duration of a firmware update may vary according to the operating system and the speed of the serial PC interface (the values shown in the table were achieved at 115.200 baud).

10.3 Accessories

The following parts can be obtained via Mitsubishi for equipping your Mitsubishi Alarm Modem.

Accessories	Description
MAM-ANT-5A	GSM magnetic rod antenna 900/1800MHz 5dB (only GM series)
MAM-ANT-ANGLE	GSM bending antenna 900/1800MHz 0 dB (only GM series)
MAM-232ADP/Blue	Blue Adapter (Nullmodem-Genderchanger, RS232, D-Sub9, plug-plug)
MAM-232ADP/Red	Red Adapter (Nullmodem-Genderchanger, RS232, D-Sub9, jack-jack)
MAM-232ADP/Brown	Brown Adapter (RS232, D-Sub9, jack-plug)
MAM-232CAB	9pin serial interface cable (plug-jack), Length: 1,80m

Tab. 10-12: Accessories

Pin assignment

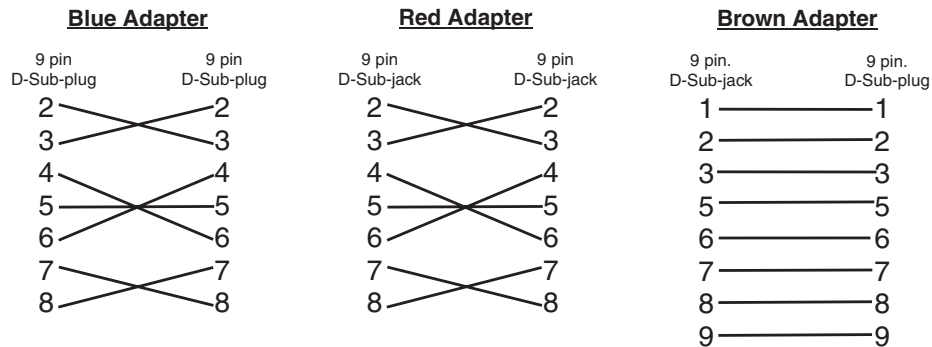

10.4 Mobile networks in Europe – USA – worldwide

- Europe: GSM networks with 900 MHz and 1800 MHz
Only GSM mobile networks are available in Europe. All networks are compatible.
The network standard only depends on the contract of your mobile network provider.
- USA: GSM networks with 850 MHz and 1900 MHz
Appropriate devices are required for GSM networks in the USA. There are additional mobile network standards in the USA (e.g. CDMA) that are not compatible with GSM. However, GSM is becoming more frequently used in the USA. For example, T-Mobile is using the GSM standard in the USA.

Worldwide: GSM is used in most countries of the world. However, some countries only use CDMA or both mobile standards.

More information on mobile networks is to be found at www.gsmworld.com.

10.5 Dimensions

10.5.1 GM series

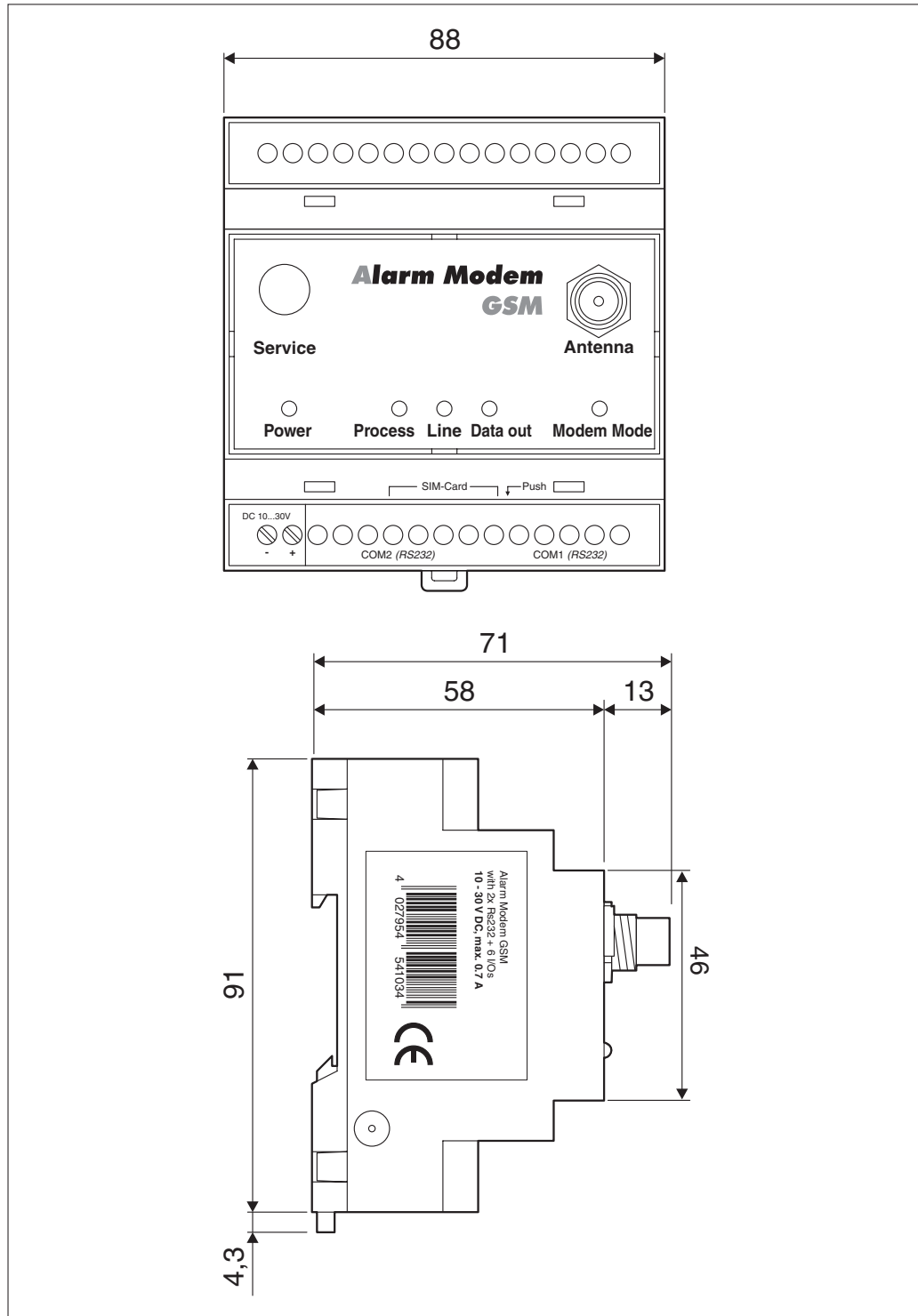

Fig. 10-1: Dimensions GM series

10.5.2 AM series

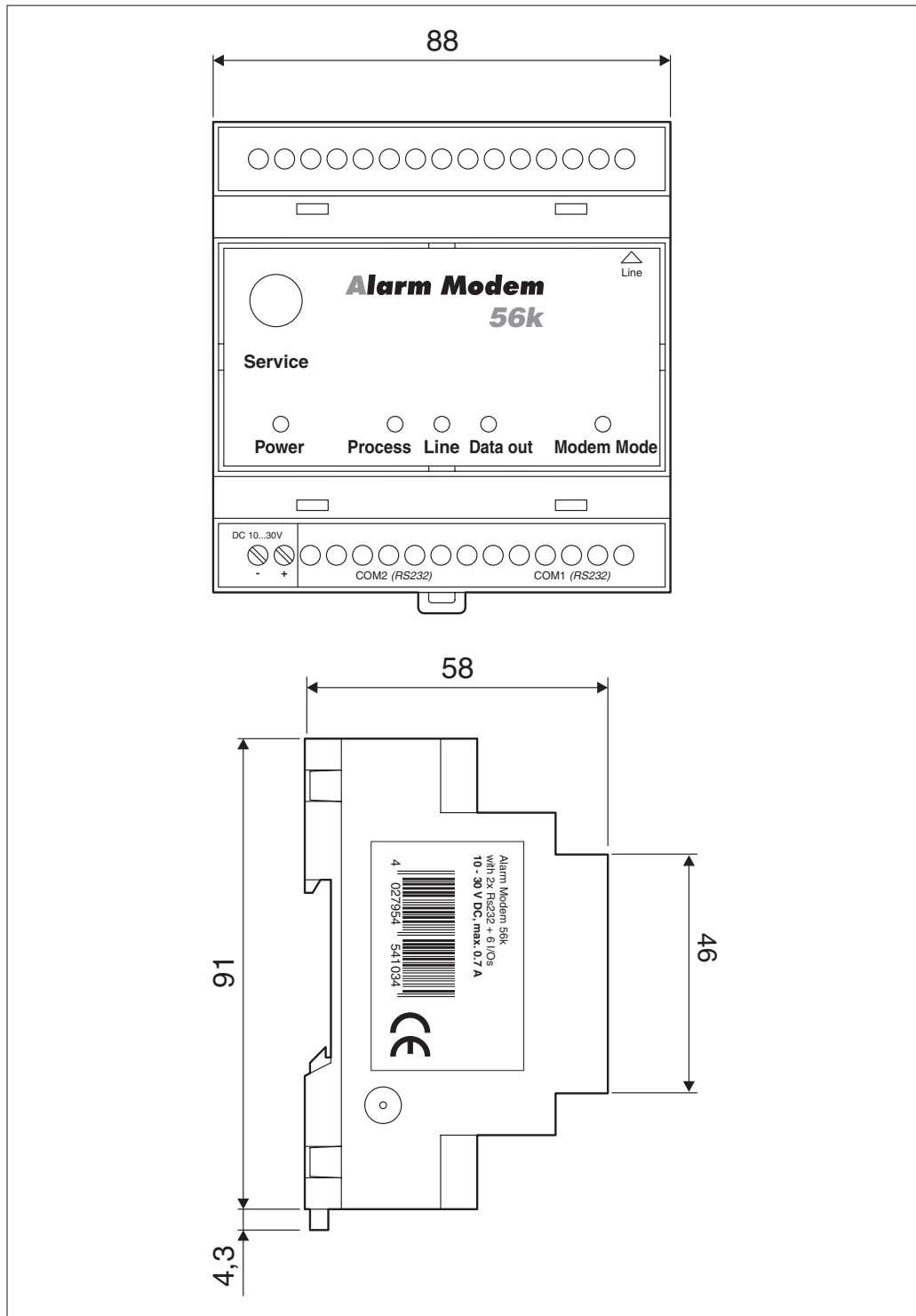

Fig. 10-2: Dimensions AM series

10.6 Terminals

10.6.1 MAM-GMx: Mitsubishi Alarm Modems GSM with RS232 and RS485

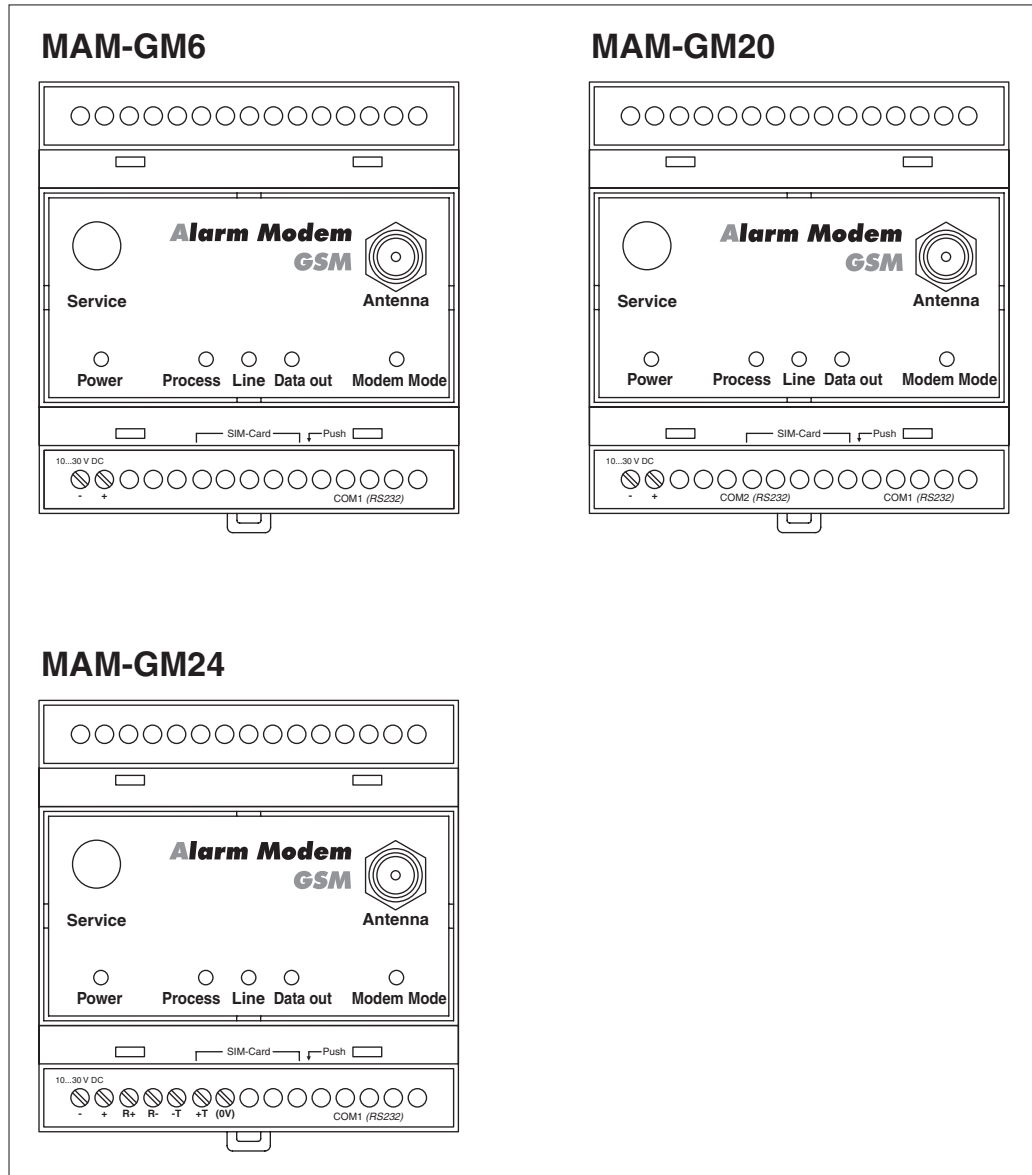

Fig. 10-3: MAM-GMx: Mitsubishi Alarm Modems GSM with RS232 and RS485

10.6.2 MAM-AMx: Mitsubishi Alarm Modems 56k with RS232 and RS485



Abb. 10-4: MAM-AMx: Mitsubishi Alarm Modems 56k with RS232 and RS485

Index

A

- Accessories 10-6
- Acknowledgment 10-1
- Alarming 2-1
- Antenna cable 3-4
- Antenna plug 3-1
- Application example 2-2
- AT commands 7-3
- AT mode 7-3

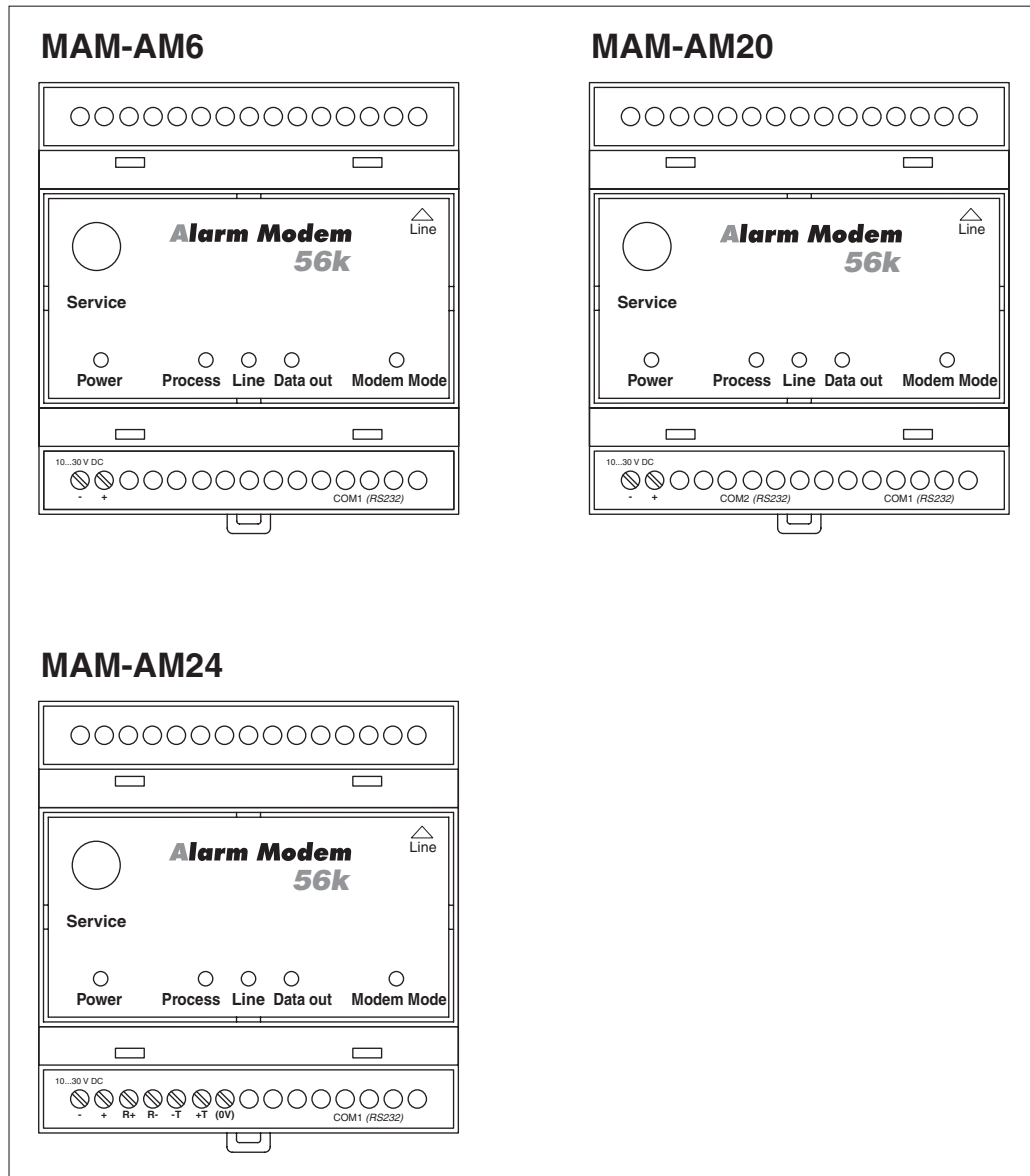
B

- Blue Adapter 4-2

C

- COM1, COM2 4-1
- Configuration 7-1
- Conformity 10-3

D

- Data triggering 2-1
- Dimensions 10-7
- DIP switches 4-3

E

- Event 10-1

F

- Factory Reset 10-4
- Firmware-Update 10-5

G

- GSM antenna 3-4

I

- Initial configuration 7-1
- Inserting the SIM card 3-5

L

- LEDs 3-2
 - during factory reset and restart 10-4
 - during Firmware-Update 10-5
 - during GSM operation 7-2
 - in the event of faults 10-4
 - Meaning 3-2
 - on restart 10-3

M

- Memory Test 6-1
- Mobile networks 10-6
- Model 2-2
- Modem Mode 7-3
- Mounting 3-3
- MX-MAE Software 8-1
 - Remote Access 8-2
 - Secure Login 8-1

O

- Operating modes 7-2

P

- PIN entry 7-1
- PLC
 - driver 9-1
 - programming software 8-2
 - protocol 2-1
- Polarity of the power supply terminals 5-1
- Project 7-1
- Project file 7-1
- Pump alarm 2-2

R

- Red Adapter 4-2
- Remote Access 8-2
- Remote switching 2-1
- Restart 10-3
- RS232 4-1
- RS422 4-2
- RS485 4-2

S

- Self-test 6-1
- Service Button 3-1
- Software MX-MAE 8-1
- SUPER PIN 7-2
- System clock 10-1

T

- Technical data 10-1
- Technische Daten 10-1
- Temperature range 10-3
- Terminals 3-1,10-8
- TiXML Mode 7-3

HEADQUARTERS

MITSUBISHI ELECTRIC EUROPE
EUROPE B.V.
German Branch
Gothaer Straße 8
D-40880 Ratingen
Phone: +49 (0) 2102 / 486-0
Fax: +49 (0) 2102 / 486-1120
e mail: megfamail@meg.mee.com

MITSUBISHI ELECTRIC FRANCE
EUROPE B.V.
French Branch
25, Boulevard des Bouvets
F-92741 Nanterre Cedex
Phone: +33 1 55 68 55 68
Fax: +33 1 55 68 56 85
e mail: factory.automation@framee.com

MITSUBISHI ELECTRIC IRELAND
EUROPE B.V.
Irish Branch
Westgate Business Park, Ballymount
IRL-Dublin 24
Phone: +353 (0) 1 / 419 88 00
Fax: +353 (0) 1 / 419 88 90
e mail: sales.info@meir.mee.com

MITSUBISHI ELECTRIC ITALY
EUROPE B.V.
Italian Branch
Via Paracelso 12
I-20041 Agrate Brianza (MI)
Phone: +39 039 6053 1
Fax: +39 039 6053 312
e mail: factory.automation@itmee.com

MITSUBISHI ELECTRIC SPAIN
EUROPE B.V.
Spanish Branch
Carretera de Rubí 76-80
E-08190 Sant Cugat del Vallés
Phone: +34 9 3 / 565 3160
Fax: +34 9 3 / 589 1579
e mail: industrial@sp.mee.com

MITSUBISHI ELECTRIC UK
EUROPE B.V.
UK Branch
Travellers Lane
GB-Hatfield Herts. AL10 8 XB
Phone: +44 (0) 1707 / 27 61 00
Fax: +44 (0) 1707 / 27 86 95
e mail: automation@meuk.mee.com

MITSUBISHI ELECTRIC CORPORATION JAPAN
Office Tower "Z" 14 F
8-12,1 chome, Harumi Chuo-Ku
Tokyo 104-6212
Phone: +81 3 6221 6060
Fax: +81 3 6221 6075

MITSUBISHI ELECTRIC AUTOMATION USA
500 Corporate Woods Parkway
Vernon Hills, IL 60061
Phone: +1 847 / 478 21 00
Fax: +1 847 / 478 22 83

MIDDLE EAST REPRESENTATIVES

ILAN & GAVISH LTD. ISRAEL
Automation Service
24 Shenkar St., Kiryat Arie
IL-49001 Petah-Tiqva
Phone: +972 (0) 3 / 922 18 24
Fax: +972 (0) 3 / 924 07 61
e mail: iandg@internet-zahav.net

TEXEL Electronics Ltd. ISRAEL
Box 6272
IL-42160 Netanya
Phone: +972 (0) 9 / 863 08 91
Fax: +972 (0) 9 / 885 24 30
e mail: texel_me@netvision.net.il

EUROPEAN REPRESENTATIVES

GEVA AUSTRIA
Wiener Straße 89
AT-2500 Baden
Phone: +43 (0) 2252 / 85 55 20
Fax: +43 (0) 2252 / 488 60
e mail: office@geva.at

TEHNIKON BELARUS
Oktjabrskaya 16/5, Ap 704
BY-220030 Minsk
Phone: +375 (0)17 / 210 4626
Fax: +375 (0)17 / 210 4626
e mail: tehnikon@belsonet.net

Koning & Hartman B.V. BELGIUM
Researchpark Zellik, Pontbeeklaan 43
BE-1731 Brussels
Phone: +32 (0)2 / 467 17 44
Fax: +32 (0)2 / 467 17 48
e mail: info@koningenhartman.com

TELECON CO. BULGARIA
Andrej Ljapchev Lbv. Pb 21 4
BG-1756 Sofia
Phone: +359 (0) 2 / 97 44 05 8
Fax: +359 (0) 2 / 97 44 06 1
e mail: —

AutoCont CZECH REPUBLIC
Control Systems s.r.o.
Nemocnicni 12
CZ-702 00 Ostrava 2
Phone: +420 59 / 6152 111
Fax: +420 59 / 6152 562
e mail: consys@autocont.cz

louis poulsen DENMARK
industri & automation
Geminivej 32
DK-2670 Greve
Phone: +45 (0) 70 / 10 15 35
Fax: +45 (0) 43 / 95 95 91
e mail: lpia@lpmail.com

UTU Elektrotehnika AS ESTONIA
Pärnu mnt.160i
EE-11317 Tallinn
Phone: +372 (0) 6 / 51 72 80
Fax: +372 (0) 6 / 51 72 88
e mail: utu@utu.ee

Beijer Electronics OY FINLAND
Ansatie 6a
FIN-01740 Vantaa
Phone: +358 (0) 9 / 886 77 500
Fax: +358 (0) 9 / 886 77 555
e mail: info@beijer.fi

UTECO A.B.E.E. GREECE
5, Mavrogenous Str.
GR-18542 Piraeus
Phone: +302 (0) 10 / 42 10 050
Fax: +302 (0) 10 / 42 12 033
e mail: sales@uteco.gr

Meltrade Ltd. HUNGARY
Fertő Utca 14.
HU-1107 Budapest
Phone: +36 (0)1 / 431-9726
Fax: +36 (0)1 / 431-9727
e mail: office@meltrade.hu

SIA POWEL LATVIA
Lienes iela 28
LV-1009 Riga
Phone: +371 784 / 22 80
Fax: +371 784 / 22 81
e mail: utu@utu.lv

EUROPEAN REPRESENTATIVES

UAB UTU POWEL LITHUANIA
Savanoriu pr. 187
LT-2053 Vilnius
Phone: +370 (0) 52323-101
Fax: +370 (0) 52322-980
e mail: powel@utu.lt

INTEHSIS SRL MOLDOVA
Cuza-Voda 36/1-81
MD-2061 Chisinau
Phone: +373 (0)2 / 562 263
Fax: +373 (0)2 / 562 263
e mail: intehsis@mdl.net

Koning & Hartman B.V. NETHERLANDS
Haarlerbergweg 21-23
NL-1101 AK Amsterdam
Phone: +31 (0)20 / 587 76 00
Fax: +31 (0)20 / 587 76 05
e mail: info@koningenhartman.com

Beijer Electronics A/S NORWAY
Teglverksveien 1
N-3002 Drammen
Phone: +47 (0) 32 / 24 30 00
Fax: +47 (0) 32 / 84 85 77
e mail: info@beijer.no

MPL Technology Sp. z o.o. POLAND
ul. Sliczna 36
PL-31-444 Kraków
Phone: +48 (0) 12 / 632 28 85
Fax: +48 (0) 12 / 632 47 82
e mail: krakow@mpl.pl

Sirius Trading & Services srl ROMANIA
Str. Biharia No. 67-77
RO-013981 Bucuresti 1
Phone: +40 (0) 21 / 201 1146
Fax: +40 (0) 21 / 201 1148
e mail: sirius@siriustrading.ro

INEA SR d.o.o. SERBIA AND MONTENEGRO
Karadjordjeva 12/260
SCG-113000 Smederevo
Phone: +381 (0)26/ 617 - 163
Fax: +381 (0)26/ 617 - 163
e mail: inea_sr@verat.net

AutoCont Control s.r.o. SLOVAKIA
Radlinského 47
SK-02601 Dolný Kubín
Phone: +421 435868 210
Fax: +421 435868 210
e mail: info@autocontcontrol.sk

INEA d.o.o. SLOVENIA
Stegne 11
SI-1000 Ljubljana
Phone: +386 (0) 1-513 8100
Fax: +386 (0) 1-513 8170
e mail: inea@inea.si

Beijer Electronics AB SWEDEN
Box 426
S-20124 Malmö
Phone: +46 (0) 40 / 35 86 00
Fax: +46 (0) 40 / 35 86 02
e mail: info@beijer.se

ECONOTEC AG SWITZERLAND
Postfach 282
CH-8309 Nürensdorf
Phone: +41 (0) 1 / 838 48 11
Fax: +41 (0) 1 / 838 48 12
e mail: info@econotec.ch

GTS TURKEY
Darülaceze Cad. No. 43 Kat. 2
TR-80270 Okmeydanı-Istanbul
Phone: +90 (0) 212 / 320 1640
Fax: +90 (0) 212 / 320 1649
e mail: gts@turk.net

CSC Automation Ltd. UKRAINE
15, M. Raskova St., Fl. 10, Office 1010
UA-02002 Kiev
Phone: +380 (0) 44 / 494 3355
Fax: +380 (0) 44 / 494 3366
e mail: csc-a@csc-a.kiev.ua

EURASIAN REPRESENTATIVES

Kazpromautomatiks Ltd. KAZAKHSTAN
2, Sladskaya Str.
KAZ-470046 Karaganda
Phone: +7 3212 50 11 50
Fax: +7 3212 50 11 50
e mail: info@kpkpkz.com

Avtomatika Sever Ltd. RUSSIA
Lva Tolstogo Str. 7, Off. 311
RU-197376 St Petersburg
Phone: +7 812 1183 238
Fax: +7 812 1183 239
e mail: as@avtsev.spb.ru

Consys Promyshlennaya St. 42 RUSSIA
RU-198099 St Petersburg
Phone: +7 812 325 3653
Fax: +7 812 147 2055
e mail: consys@consys.spb.ru

Electrotechnical Systems Siberia RUSSIA
Shetinkina St. 33, Office 116
RU-630088 Novosibirsk
Phone: +7 3832 / 119598
Fax: +7 3832 / 119598
e mail: info@eltechsystems.ru

Elektrostyle RUSSIA
Poslannikov Per., 9, Str.1
RU-107005 Moscow
Phone: +7 095 542 4323
Fax: +7 095 956 7526
e mail: info@estl.ru

Elektrostyle RUSSIA
Krasnij Prospekt 220-1, Office No. 312
RU-630049 Novosibirsk
Phone: +7 3832 / 106618
Fax: +7 3832 / 106626
e mail: info@estl.ru

ICOS RUSSIA
Industrial Computer Systems Zao
Ryazanskij Prospekt, 8A, Off. 100
RU-109428 Moscow
Phone: +7 095 232 0207
Fax: +7 095 232 0327
e mail: mail@icos.ru

NPP Uralelektra RUSSIA
Sverdlova 11A
RU-620027 Ekaterinburg
Phone: +7 34 32 / 532745
Fax: +7 34 32 / 532745
e mail: elektra@etel.ru

STC Drive Technique RUSSIA
Poslannikov Per., 9, Str.1
RU-107005 Moscow
Phone: +7 095 790 7210
Fax: +7 095 790 7212
e mail: info@privod.ru

AFRICAN REPRESENTATIVE

CBI Ltd. SOUTH AFRICA
Private Bag 2016
ZA-1600 Isando
Phone: +27 (0) 11 / 928 2000
Fax: +27 (0) 11 / 392 2354
e mail: cbi@cbi.co.za